

Split type room air conditioner
Wall mounted type



SERVICE MANUAL

Indoor unit	Outdoor unit
RSG18KMTA	ROG18KMTA
RSG24KMTA	ROG24KMTA



CONTENTS

SPECIFICATIONS	1
DIMENSIONS	4
REFRIGERANT SYSTEM DIAGRAM	7
PCB CIRCUIT DIAGRAM	9
ERROR DETECTION	12
PARTS (INDOOR UNIT)	13
PARTS (OUTDOOR UNIT)	22
ACCESSORIES	34

Specifications (Indoor unit)

Type				Wall mounted		
				Inverter heat pump		
Model name				RSG18KMTA	RSG24KMTA	
Power supply				230 V ~ 50 Hz		
Power supply intake				Outdoor unit		
Available voltage range				198—264 V		
Capacity	Cooling	Rated	kW	5.20	7.10	
			Btu/h	17,700	24,200	
		Min.—Max.	kW	0.90—6.00	0.90—8.30	
			Btu/h	3,100—20,500	3,100—28,300	
	Heating	Rated	kW	6.30	8.00	
			Btu/h	21,500	27,200	
Min.—Max.		kW	0.90—8.70	0.90—10.10		
		Btu/h	3,100—29,600	3,100—34,400		
Input power	Cooling	Rated	kW	1.39	2.08	
				Min.—Max.	0.09—1.66	0.24—3.15
	Heating	Rated	kW	1.56	1.91	
				Min.—Max.	0.09—2.86	0.14—3.00
	Fan	HIGH	W	37.5	61.6	
				MED	22.9	26.7
				LOW	13.3	13.3
				QUIET	8.2	8.2
Current	Cooling	Rated	A	6.1	9.3	
	Heating			7.0	8.6	
EER	Cooling			3.74	3.41	
COP	Heating			4.04	4.19	
Sensible capacity	Cooling			4.05	5.30	
Power factor	Cooling			98	98	
	Heating			98	96	
Moisture removal			L/h (pints/h)	1.7 (3.0)	2.7 (4.8)	
Maximum operating current *1	Cooling			9.5	13.5	
	Heating			13.5	16.0	
Fan	Cooling	HIGH	m ³ /h	980	1,170	
				MED	810	850
				LOW	640	640
				QUIET	510	510
	Heating	HIGH	1,020	1,170		
			MED	850	850	
			LOW	640	640	
			QUIET	510	510	
Type × Q'ty			Cross flow fan × 1			
Motor output			W			
Sound pressure level *2	Cooling	HIGH	dB (A)	45	49	
				MED	40	40
				LOW	35	35
				QUIET	29	29
	Heating	HIGH	46	49		
			MED	40	40	
			LOW	35	35	
			QUIET	29	29	
Heat exchanger type	Dimensions (H × W × D)		mm	Main1: 210 × 798 × 26.6, Main2: 135 × 798 × 20 Sub1: 84 × 798 × 13.3, Sub2: 84 × 798 × 13.3		
	Fin pitch			Main1: 1.2, Main2: 1.1 Sub1: 1.4, Sub2: 1.4		
	Rows × Stages			Main1: 2 × 10, Main2: 2 × 8 Sub1: 1 × 4, Sub2: 1 × 4		
	Pipe type			Copper		
	Fin type			Aluminum		
Enclosure	Material		Polystyrene			
	Color		White Approximate color of Munsell N 9.25/			
Dimensions (H × W × D)	Net	mm	280 × 980 × 240			
	Gross		322 × 1,078 × 346			
Weight	Net	kg	13.0			
	Gross		18			
Connection pipe	Size	Liquid	Ø 6.35 (Ø 1/4)			
		Gas	Ø 12.70 (Ø 1/2)			
Drain hose	Material			PP + HDPE		
	Size	mm	Ø 13.8 (I.D.), Ø 15.8 to Ø 16.7 (O.D.)			
Operation range	Cooling			18 to 32		
				80 or less		
Remote control	Heating			16 to 30		
				Wireless remote controller (Option: Wired remote controller, Mobile app*3 [FGLair™])		

NOTES:

- Specifications are based on the following conditions:
 - Cooling: Indoor temperature of 27 °CDB/19 °CWB, and outdoor temperature of 35 °CDB/24 °CWB.
 - Heating: Indoor temperature of 20 °CDB/15 °CWB, and outdoor temperature of 7 °CDB/6 °CWB.
 - Pipe length: 5 m, Height difference: 0 m. (Between outdoor unit and indoor unit.)
- Protective function might work when using it outside the operation range.
- *1: Maximum operating current is the total current of the indoor unit and the outdoor unit.
- *2: Sound pressure level:
 - Measured values in manufacturer's anechoic chamber.
 - Because of the surrounding sound environment, the sound levels measured in actual installation conditions might be higher than the specified values here.
- *3: Available on Google Play™ store or on App Store®. Optional WLAN adapter is also required. For details, refer to the setting manual.

Specifications (Indoor unit) continues

Specifications for ErP Lot10				
Model name		RSG18KMTA		RSG24KMTA
Energy efficiency class	Cooling	A ⁺⁺		
	Heating (Average)	A ⁺		
Pdesign	Cooling	kW	5.2 (35°C)	7.1 (35°C)
	Heating (Average)		4.8 (-10°C)	7.1 (-10°C)
SEER	Cooling	kWh/kWh	7.77	7.28
SCOP	Heating (Average)		4.56	4.18
Annual energy consumption	QCE	kWh/a	234	341
	QHE (Average)		1,472	2,372
Sound power level	Cooling	HIGH	dB (A)	60
	Heating			61

Specifications (Outdoor unit)

Type			Inverter heat pump		
Model name			ROG18KMTA	ROG24KMTA	
Power supply			230 V ~ 50 Hz		
Power supply intake			Outdoor unit		
Available voltage range			198—264 V		
Starting current			A		
			7.0	8.6	
Fan	Airflow rate	Cooling	m ³ /h	2,350	3,240
		Heating		2,100	2,820
	Type × Q'ty	Propeller fan × 1			
Motor output			W	49	
Sound pressure level *1			Cooling	50	54
			Heating	50	52
Sound power level			Cooling	65	67
			Heating	65	66
Heat exchanger type			Dimensions (H × W × D)	588 × 881 × 18.19	672 × 881 × 18.19
			588 × 851 × 18.19	672 × 851 × 18.19	
			Fin pitch	1.3	
			Rows × Stages	1 × 28	1 × 32
			Pipe type	Copper tube	
			Fin type	Aluminum	
			Type (Material)	PC fin	
			Surface treatment		
Compressor			Type	DC twin rotary	
			Motor output	W	900
				1,060	
Refrigerant			Type (Global warming potential)	R32 (675)	
			Charge	g	1,020
Refrigerant oil			Type	FW68S	RmM68AF
			Amount	cm ³	350
					400
Enclosure			Material	Steel sheet	
			Color	Beige	
				Approximate color of Munsell 10YR 7.5/1.0	
Dimensions (H × W × D)			Net	632 × 799 × 290	716 × 820 × 315
			Gross	692 × 940 × 375	776 × 961 × 450
Weight			Net	36	42
			Gross	40	46
Connection pipe			Size	Liquid	mm (in)
				Gas	Ø 6.35 (Ø 1/4)
					Ø 12.70 (Ø 1/2)
			Method	Flare	
			Pre-charge length	15	
			Max. length	25	30
			Max. height difference	20	25
Operation range			Cooling	-10 to 46	
			Heating	-15 to 24	
Drain hose			Material	PP	
			Size	mm	
				Ø 13.0 (I. D.), Ø 16.0 to Ø 16.7 (O. D.)	
NOTES:					
<ul style="list-style-type: none"> • Specifications are based on the following conditions: <ul style="list-style-type: none"> – Cooling: Indoor temperature of 27 °CDB/19 °CWB, and outdoor temperature of 35 °CDB/24 °CWB. – Heating: Indoor temperature of 20 °CDB/15 °CWB, and outdoor temperature of 7 °CDB/6 °CWB. – Pipe length: 5 m, Height difference: 0 m. • Protective function might work when using it outside the operation range. • *1: Sound pressure level <ul style="list-style-type: none"> – Measured values in manufacturer's anechoic chamber. – Because of the surrounding sound environment, the sound levels measured in actual installation conditions might be higher than the specified values here. 					

Dimensions

Models: RSG18KMTA and RSG24KMTA

Unit: mm

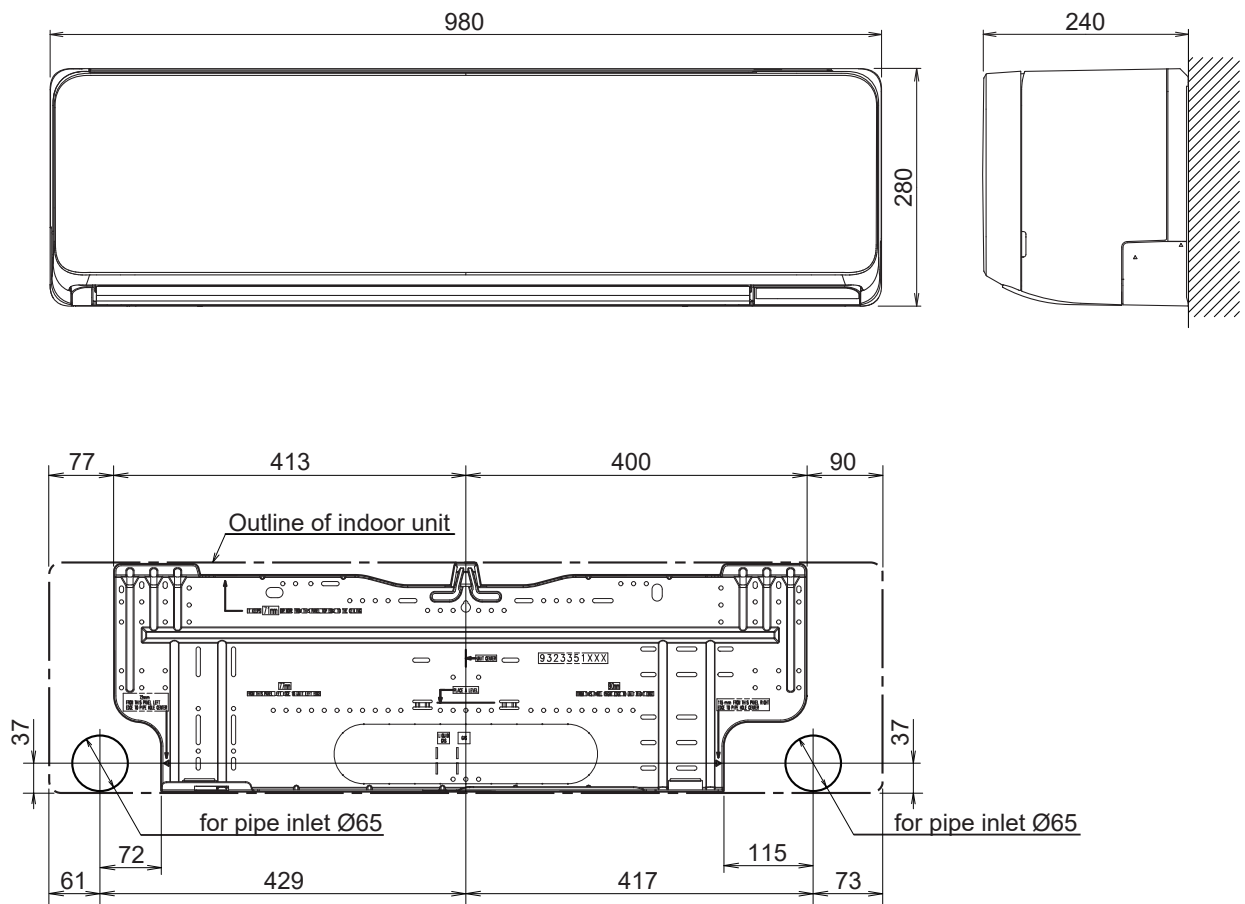

Model: ROG18KMTA

Unit: mm

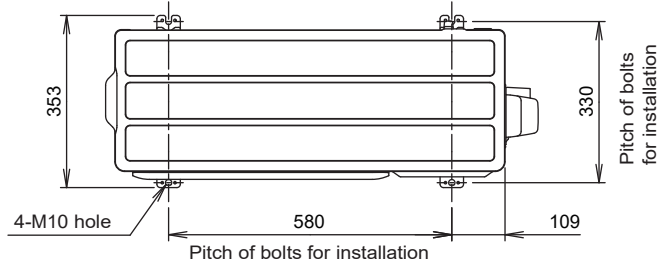

Top view

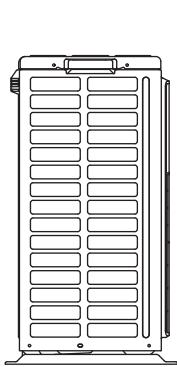

Side view

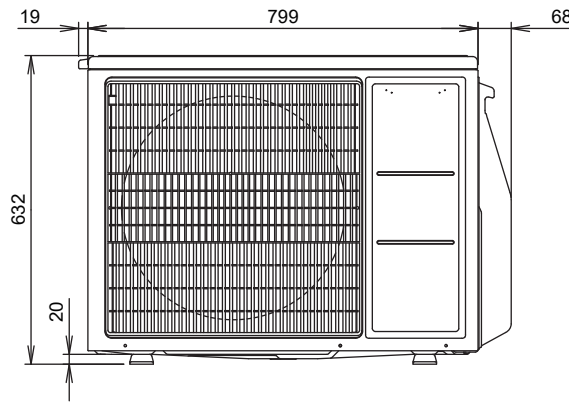

Front view

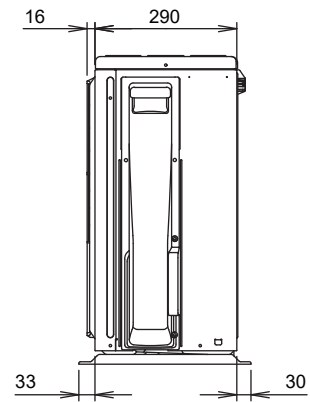

Side view

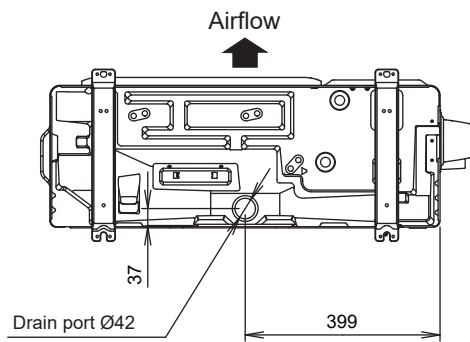

Bottom view

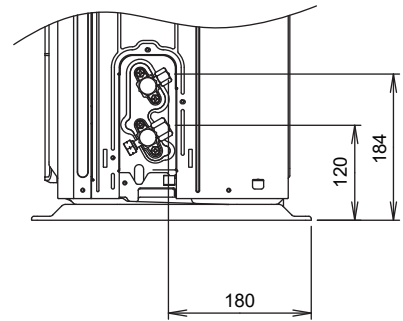

Side view (Valve part)

Model: ROG24KMTA

Unit: mm

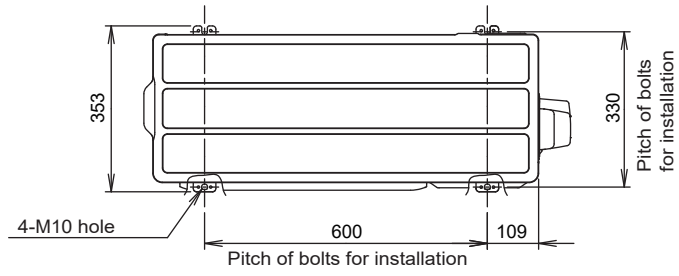

Top view

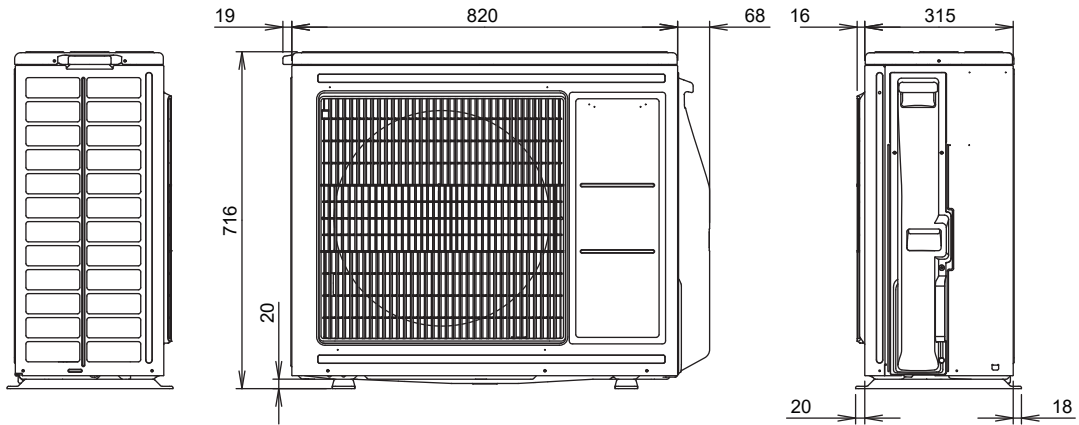

Side view

Front view

Side view

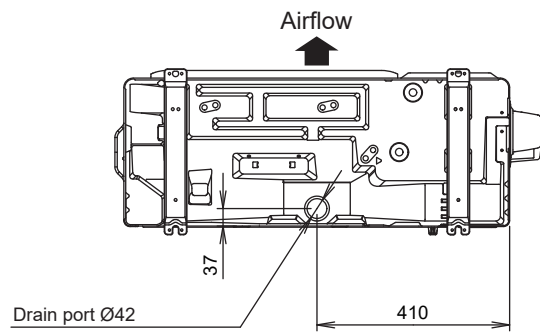

Bottom view

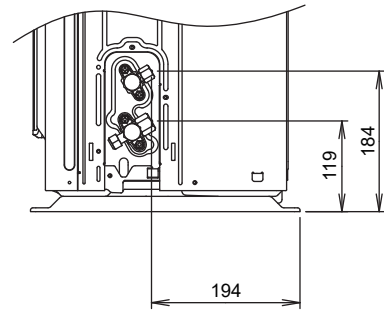

Side view (Valve part)

Refrigerant circuit

Models: RSG18KMTA/ROG18KMTA

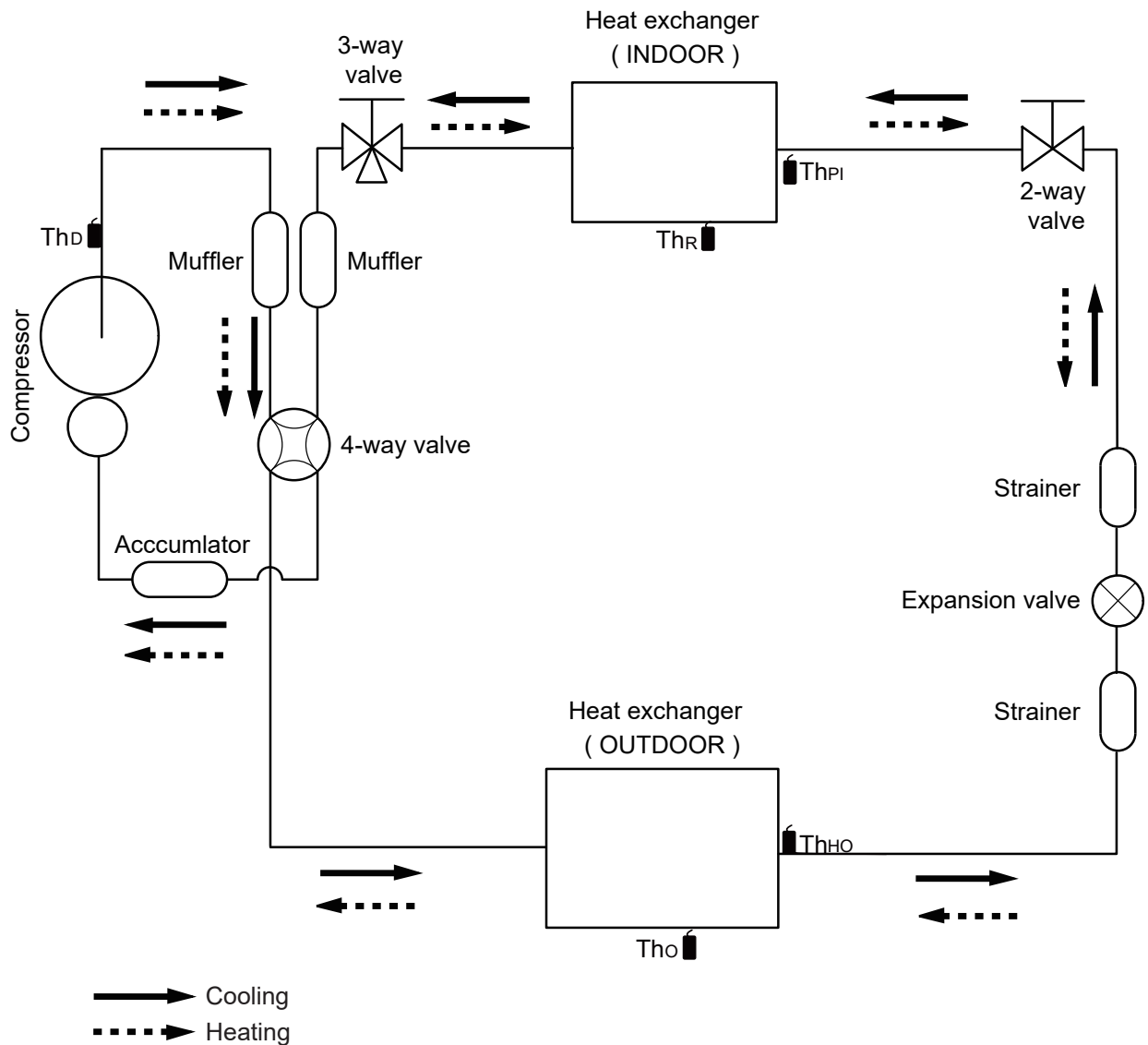

- Th_D : Thermistor (Discharge temperature)
- Th_O : Thermistor (Outdoor temperature)
- Th_{HO} : Thermistor (Heat exchanger out temperature)
- Th_R : Thermistor (Room temperature)
- Th_{PI} : Thermistor (Pipe temperature)

Models: RSG24KMTA/ROG24KMTA

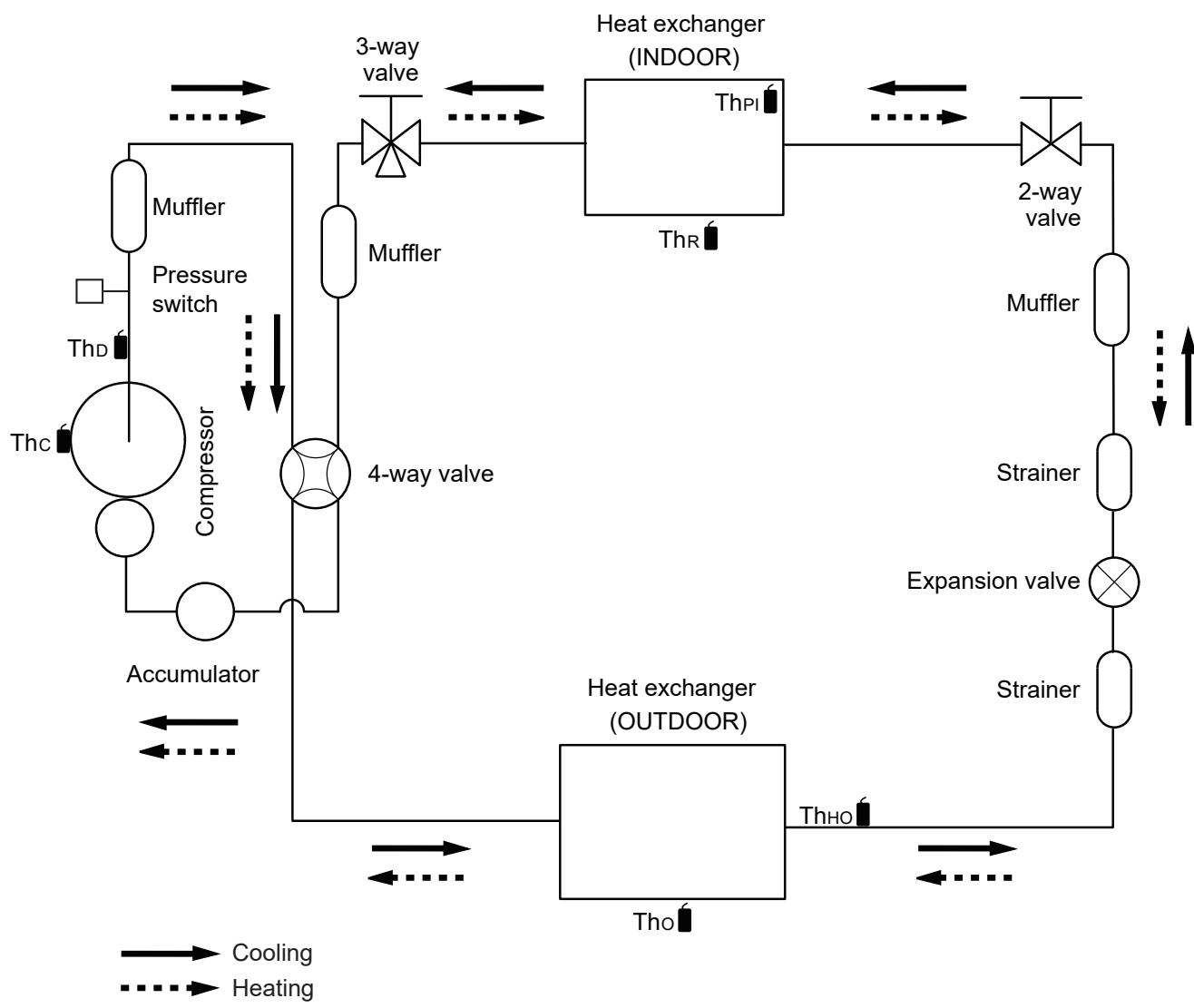

- Thc : Thermistor (Compressor temperature)
- Thd : Thermistor (Discharge temperature)
- Tho : Thermistor (Outdoor temperature)
- ThHo : Thermistor (Heat exchanger out temperature)
- ThR : Thermistor (Room temperature)
- ThPI : Thermistor (Pipe temperature)

INDOOR PRINTED CIRCUIT BOARD CIRCUIT DIAGRAM

Models : RSG18KMTA
RSG24KMTA

CONTROL UNIT
RSG18KMTA : EZ-0183AHSE
RSG24KMTA : EZ-0183BHSE

CN5 DC Fan motor

Pin No.	Terminal code	Function of terminal	Lead wire color
1	Vm	Motor power voltage input	Red
2	---	---	---
3	---	---	---
4	GND	GND	Black
5	Vcc	Control power voltage input	White
6	Vsp	Speed control voltage input	Yellow
7	FG	Revolution pulse output	Blue

2-WIRE REMOTE CONTROL UNIT (OPTION)
UTY-TWRXZ2

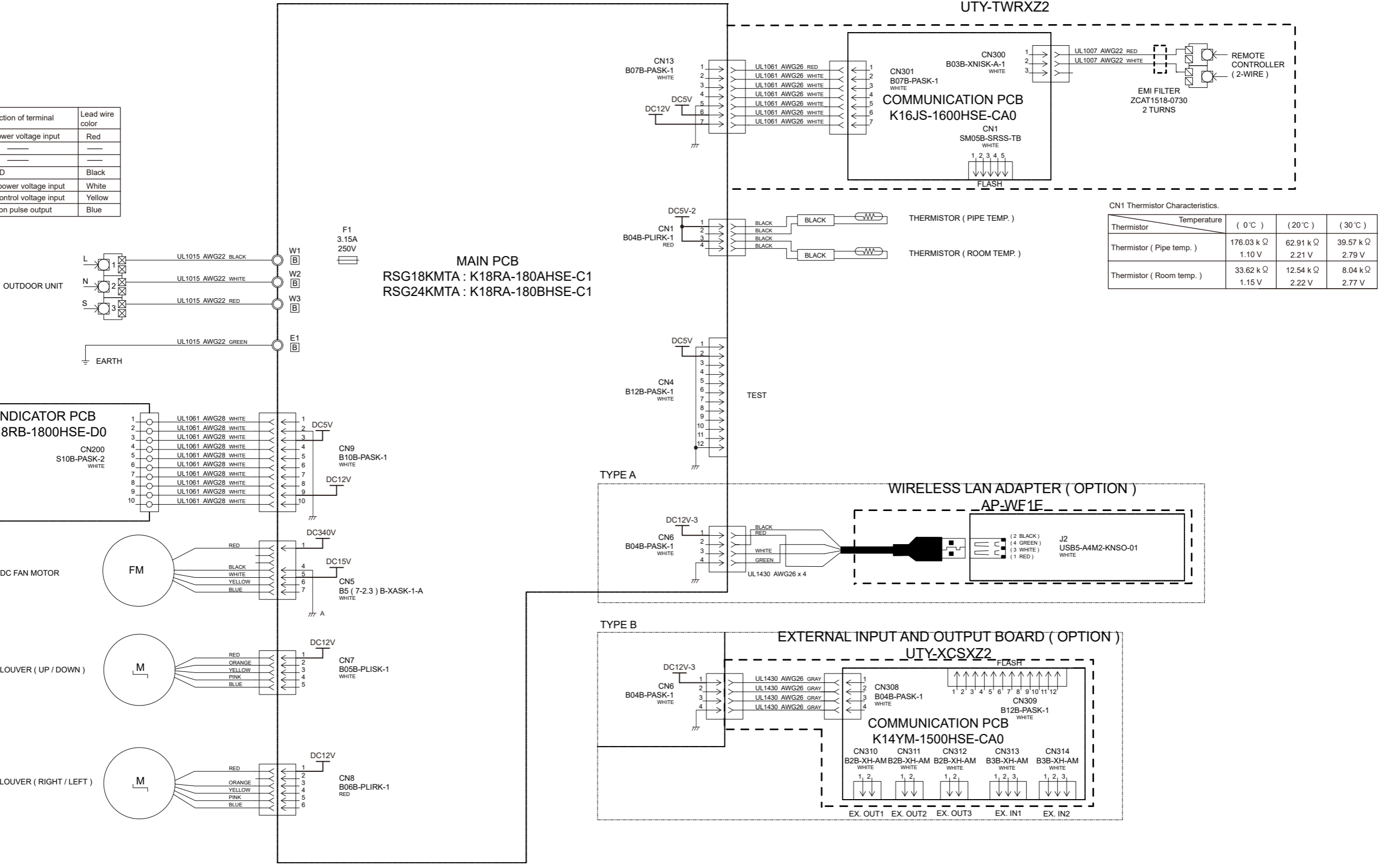

OUTDOOR PRINTED CIRCUIT BOARD CIRCUIT DIAGRAM

Model : ROG18KMTA

INVERTER ASSEMBLY EZ-01827HUE

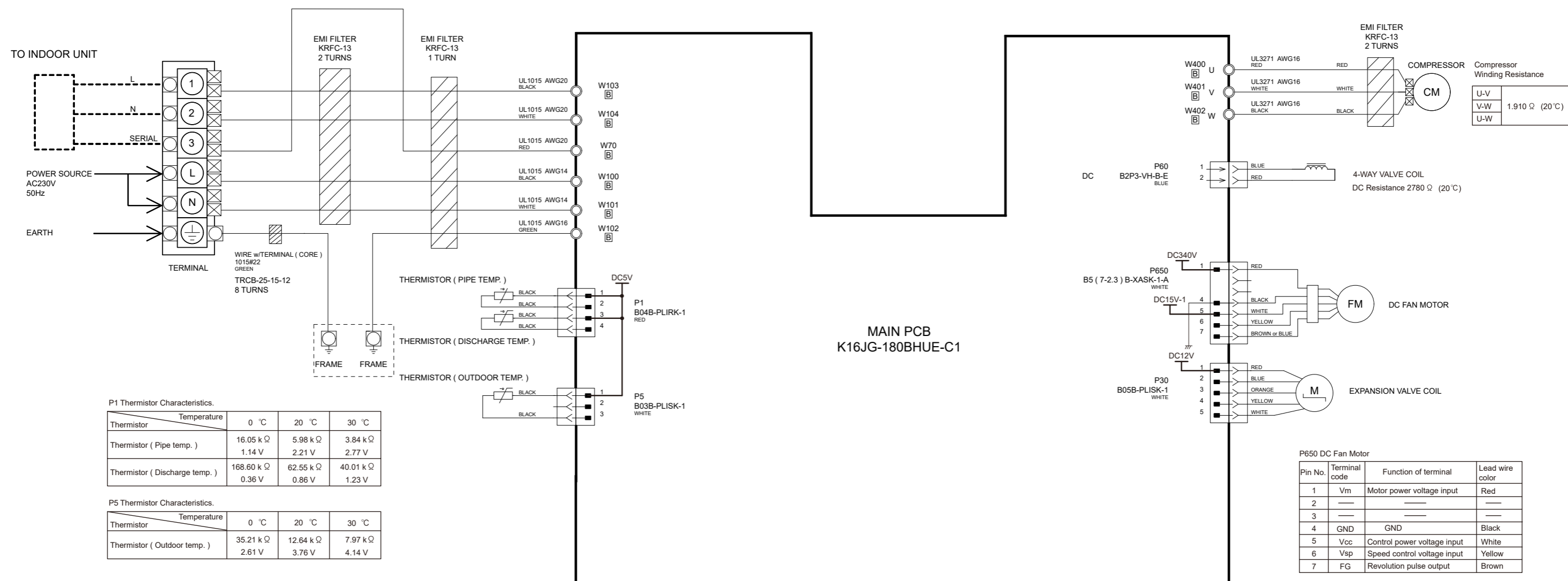

Compressor Winding Resistance

U-V	1.910 Ω (20°C)
V-W	
U-W	

P1 Thermistor Characteristics.

Thermistor	Temperature	0 °C	20 °C	30 °C
Thermistor (Pipe temp.)		16.05 k Ω	5.98 k Ω	3.84 k Ω
		1.14 V	2.21 V	2.77 V
Thermistor (Discharge temp.)		168.60 k Ω	62.55 k Ω	40.01 k Ω
		0.36 V	0.86 V	1.23 V

P5 Thermistor Characteristics.

Thermistor	Temperature	0 °C	20 °C	30 °C
Thermistor (Outdoor temp.)		35.21 k Ω	12.64 k Ω	7.97 k Ω
		2.61 V	3.76 V	4.14 V

P650 DC Fan Motor

Pin No.	Terminal code	Function of terminal	Lead wire color
1	Vm	Motor power voltage input	Red
2	---	---	---
3	---	---	---
4	GND	GND	Black
5	Vcc	Control power voltage input	White
6	Vsp	Speed control voltage input	Yellow
7	FG	Revolution pulse output	Brown

P30 Expansion Valve Coil
Recommended Drive Condition
Unipolar Drive, 1-2 Phase Excitation.

1(Red) - 2(Blue)	Coil resistance ≈ 46.0 Ω (20 °C)
1(Red) - 3(Orange)	
1(Red) - 4(Yellow)	
1(Red) - 5(White)	

INVERTER ASSEMBLY
EZ-0182YHUE

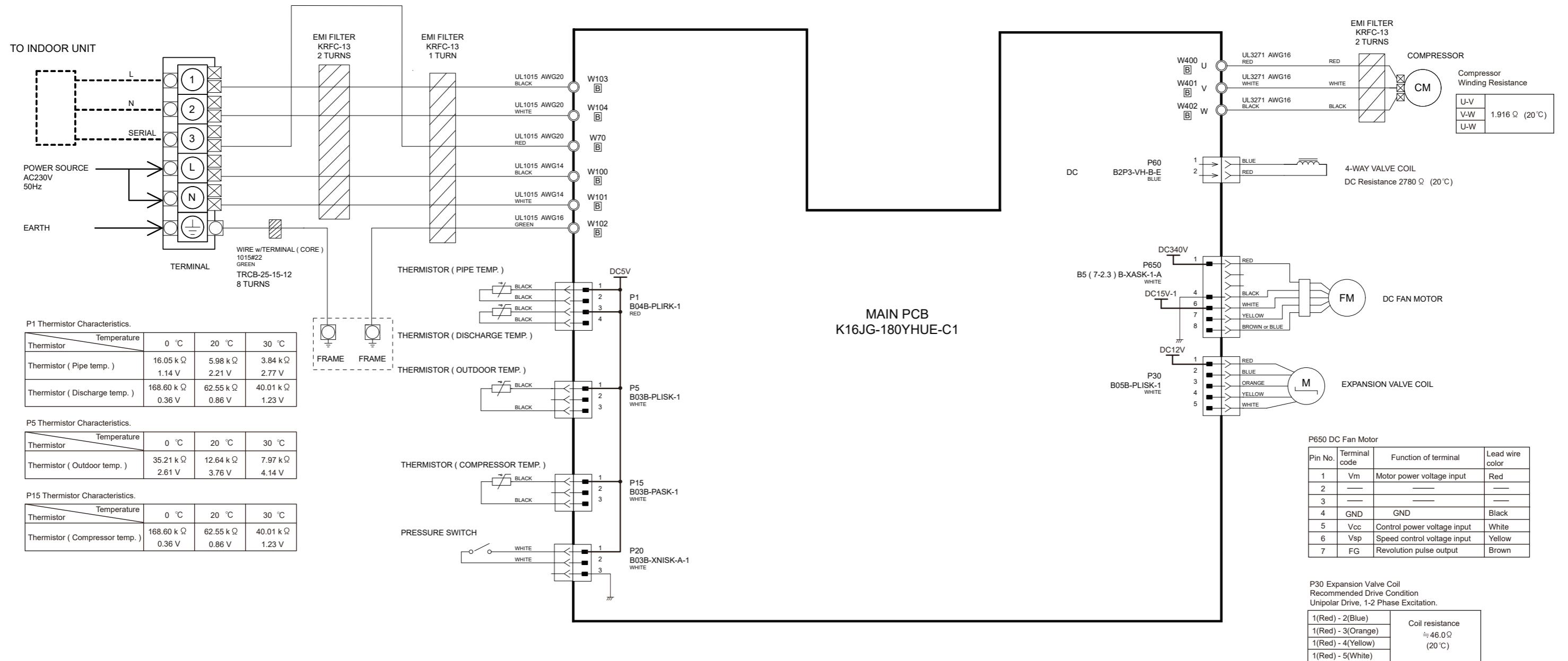

P1 Thermistor Characteristics.

Thermistor	Temperature	0 °C	20 °C	30 °C
Thermistor (Pipe temp.)		16.05 k Ω	5.98 k Ω	3.84 k Ω
		1.14 V	2.21 V	2.77 V
Thermistor (Discharge temp.)		168.60 k Ω	62.55 k Ω	40.01 k Ω
		0.36 V	0.86 V	1.23 V

P5 Thermistor Characteristics.

Thermistor	Temperature	0 °C	20 °C	30 °C
Thermistor (Outdoor temp.)		35.21 k Ω	12.64 k Ω	7.97 k Ω
		2.61 V	3.76 V	4.14 V

P15 Thermistor Characteristics.

Thermistor	Temperature	0 °C	20 °C	30 °C
Thermistor (Compressor temp.)		168.60 k Ω	62.55 k Ω	40.01 k Ω
		0.36 V	0.86 V	1.23 V

P650 DC Fan Motor

Pin No.	Terminal code	Function of terminal	Lead wire color
1	Vm	Motor power voltage input	Red
2	—	—	—
3	—	—	—
4	GND	GND	Black
5	Vcc	Control power voltage input	White
6	Vsp	Speed control voltage input	Yellow
7	FG	Revolution pulse output	Brown

P30 Expansion Valve Coil
Recommended Drive Condition
Unipolar Drive, 1-2 Phase Excitation.

1(Red) - 2(Blue)	Coil resistance ≈ 46.0 Ω (20 °C)
1(Red) - 3(Orange)	
1(Red) - 4(Yellow)	
1(Red) - 5(White)	

Error detection

Error display			Error code	Description
OPERATION lamp (green)	TIMER lamp (orange)	ECONOMY lamp (green)		
●(2)	●(6)	◇	26	Indoor unit address setting error
●(2)	●(7)	◇	27	Primary unit, secondary unit setup error [Simultaneous Multi]
●(2)	●(9)	◇	29	Connection unit number error in wired remote controller system
●(3)	●(1)	◇	31	Power supply interruption error
●(3)	●(2)	◇	32	Indoor unit PCB model information error
●(3)	●(3)	◇	33	Indoor unit motor electricity consumption detection error
●(3)	●(5)	◇	35	Manual auto switch error
●(3)	●(9)	◇	39	Indoor unit power supply error for fan motor
●(3)	●(10)	◇	3A	Indoor unit communication circuit (wired remote controller) error
●(4)	●(1)	◇	41	Room temp. sensor error
●(4)	●(2)	◇	42	Indoor unit heat ex. middle temp. sensor error
●(5)	●(1)	◇	51	Indoor unit fan motor error
●(5)	●(3)	◇	53	Drain pump error
●(5)	●(4)	◇	54	Electric air cleaner reverse VDD error
●(5)	●(5)	◇	55	Filter set error
●(5)	●(7)	◇	57	Damper error
●(5)	●(8)	◇	58	Intake grille error
●(5)	●(9)	◇	59	Indoor unit fan motor 2 error (Left side fan)
●(5)	●(10)	◇	5A	Indoor unit fan motor 3 error (Right side fan)
●(5)	●(15)	◇	5U	Indoor unit error
●(6)	●(1)	◇	61	Outdoor unit reverse/missing phase and wiring error
●(6)	●(2)	◇	62	Outdoor unit main PCB model information error or communication error
●(6)	●(3)	◇	63	Inverter error
●(6)	●(4)	◇	64	Active filter error, PFC circuit error
●(6)	●(5)	◇	65	Trip terminal L error
●(6)	●(8)	◇	68	Outdoor unit rush current limiting resistor temp. rise error
●(6)	●(10)	◇	6A	Display PCB microcomputers communication error
●(7)	●(1)	◇	71	Discharge temp. sensor error
●(7)	●(2)	◇	72	Compressor temp. sensor error
●(7)	●(3)	◇	73	Outdoor unit Heat Ex. liquid temp. sensor error
●(7)	●(4)	◇	74	Outdoor temp. sensor error
●(7)	●(5)	◇	75	Suction Gas temp. sensor error
●(7)	●(6)	◇	76	• 2-way valve temp. sensor error • 3-way valve temp. sensor error
●(7)	●(7)	◇	77	Heat sink temp. sensor error

Error display			Error code	Description
OPERATION lamp (green)	TIMER lamp (orange)	ECONOMY lamp (green)		
●(8)	●(2)	◇	82	• Sub-cool Heat Ex. gas inlet temp. sensor error • Sub-cool Heat Ex. gas outlet temp. sensor error
●(8)	●(3)	◇	83	Liquid pipe temp. sensor error
●(8)	●(4)	◇	84	Current sensor error
●(8)	●(6)	◇	86	• Discharge pressure sensor error • Suction pressure sensor error • High pressure switch error
●(9)	●(4)	◇	94	Trip detection
●(9)	●(5)	◇	95	Compressor rotor position detection error (permanent stop)
●(9)	●(7)	◇	97	Outdoor unit fan motor 1 error
●(9)	●(8)	◇	98	Outdoor unit fan motor 2 error
●(9)	●(9)	◇	99	4-way valve error
●(9)	●(10)	◇	9A	Coil (expansion valve) error
●(10)	●(1)	◇	A1	Discharge temp. error
●(10)	●(3)	◇	A3	Compressor temp. error
●(10)	●(4)	◇	A4	High pressure error
●(10)	●(5)	◇	A5	Low pressure error
●(13)	●(2)	◇	J2	Branch boxes error [Flexible Multi]

Display mode ● : 0.5s ON / 0.5s OFF
 ◇ : 0.1s ON / 0.1s OFF
 () : Number of flashing

■ Error display on the indoor unit

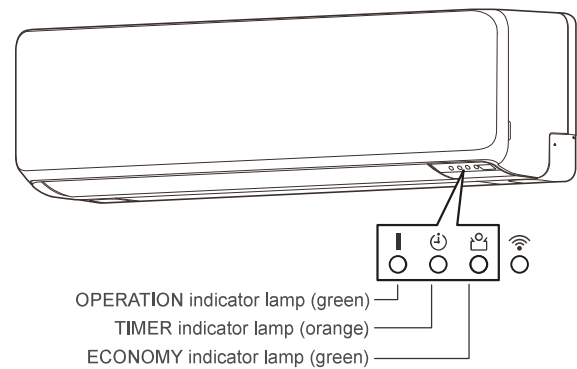

Parts

INDOOR UNIT
RSG18KMTA
RSG24KMTA

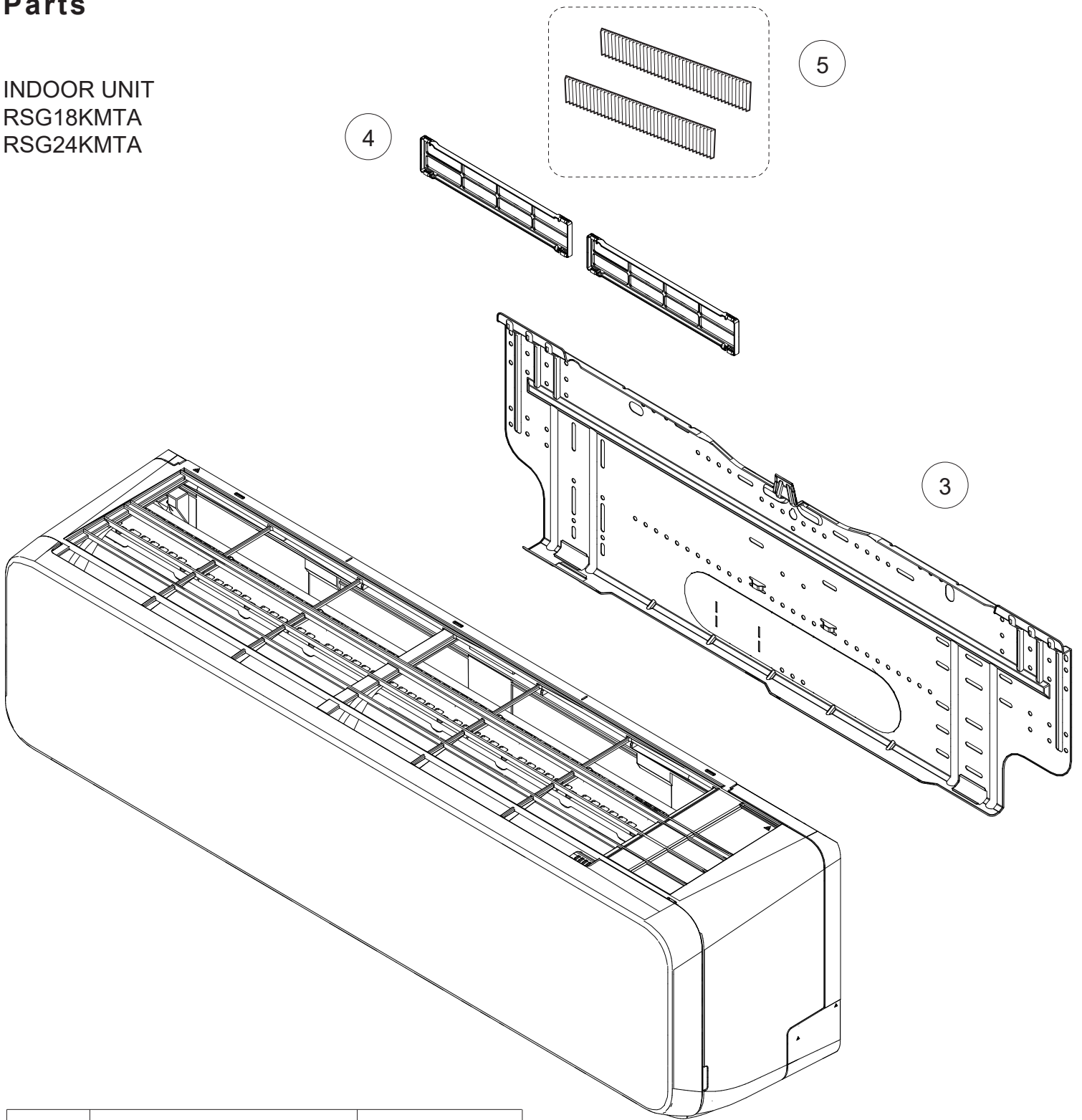

Ref.	Description	Part number
1	Remote control (no brand)	9383712012
2	Remote control holder	9318912005
3	Bracket panel	9323351004
4	Electric filter holder	9332911008
5	Air clean filter assy	9317250009

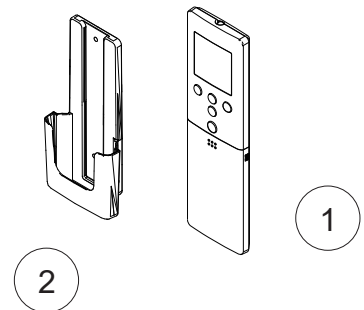

INDOOR UNIT
RSG18KMTA
RSG24KMTA

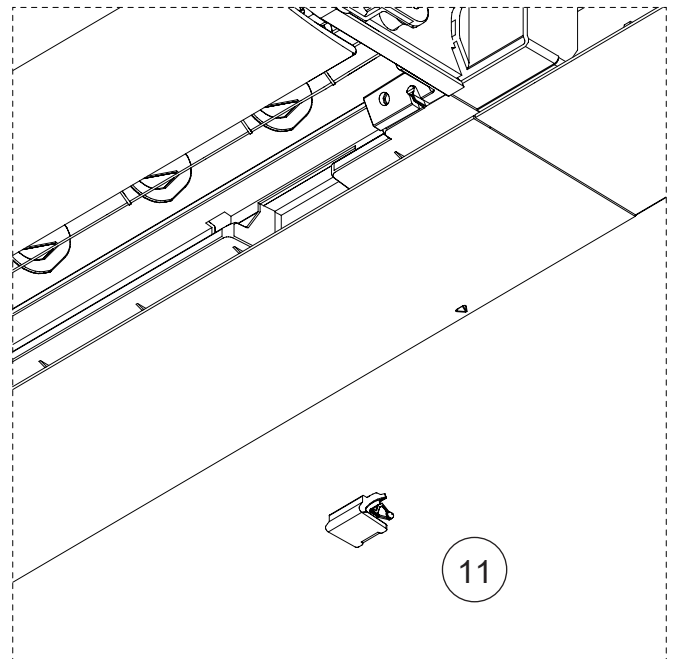
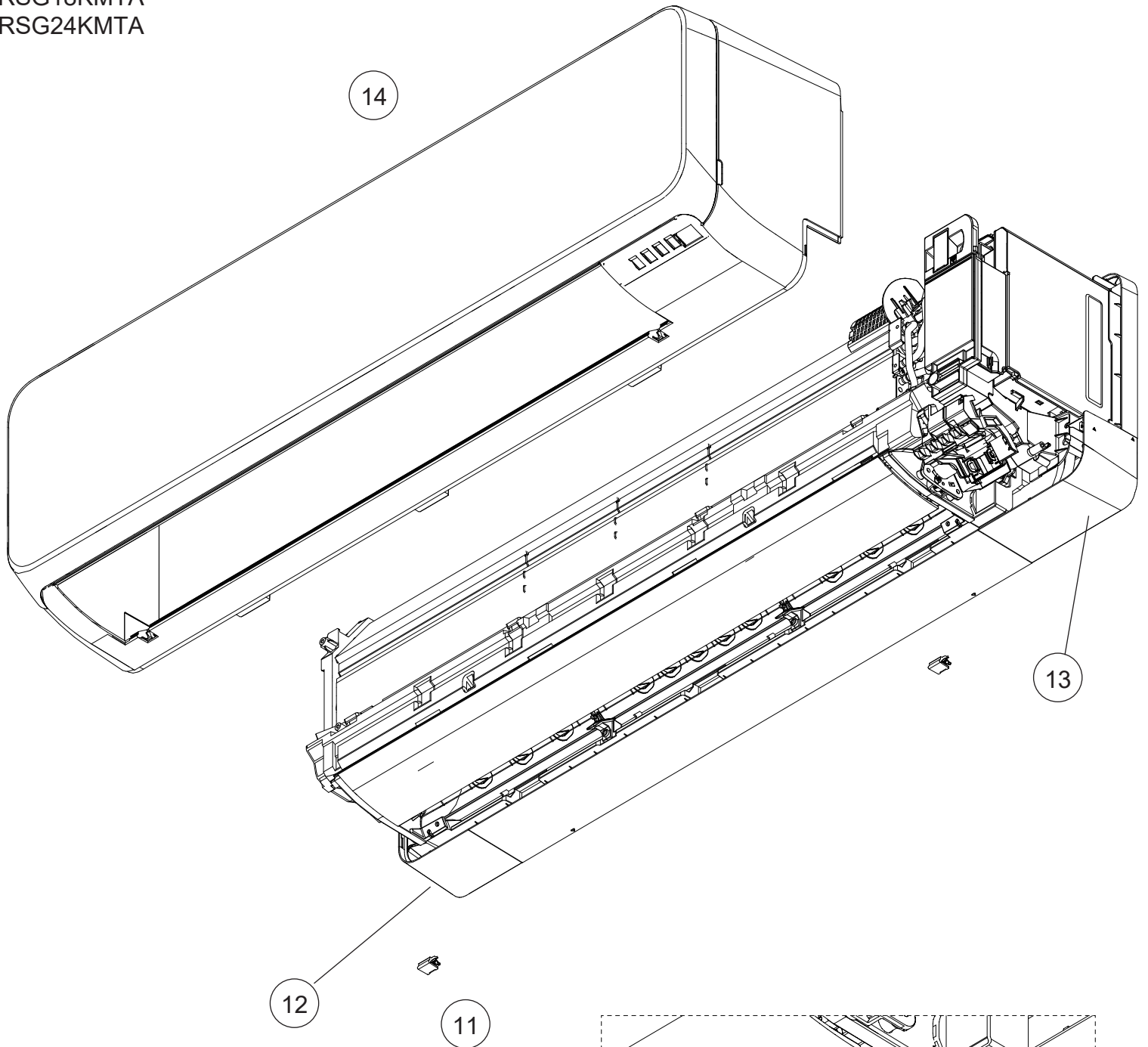

Ref.	Description	Part number
11	Screw cap	9387476002
12	Under cover L	9323341012
13	Under cover R	9323342019
14	Front panel total assy	9387596274

INDOOR UNIT
RSG18KMTA
RSG24KMTA

Front panel total assy

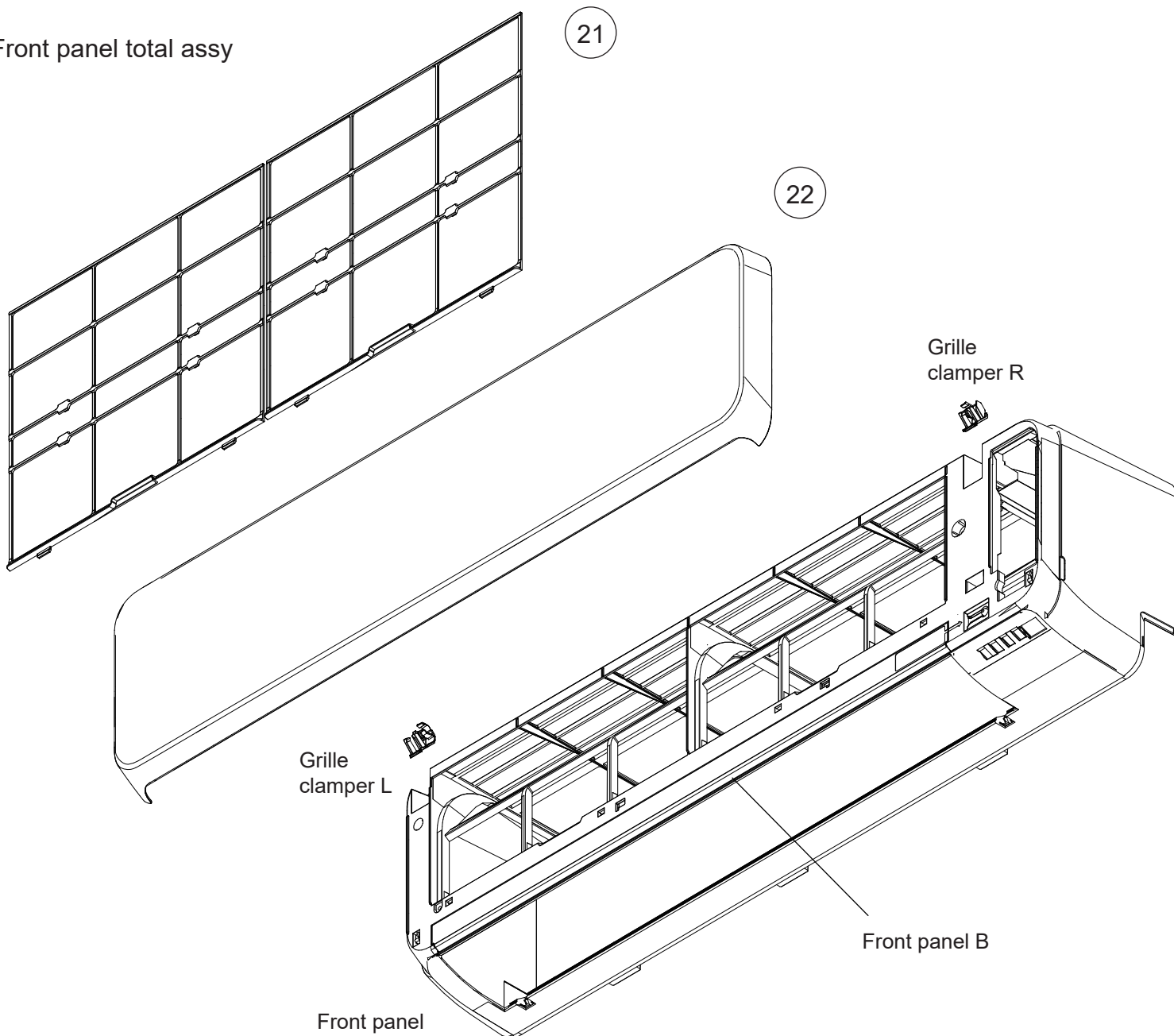

Ref.	Description	Part number
21	Air filter	9323340008
22	Intake grille assy (FUJI ELECTRIC)	9387756104

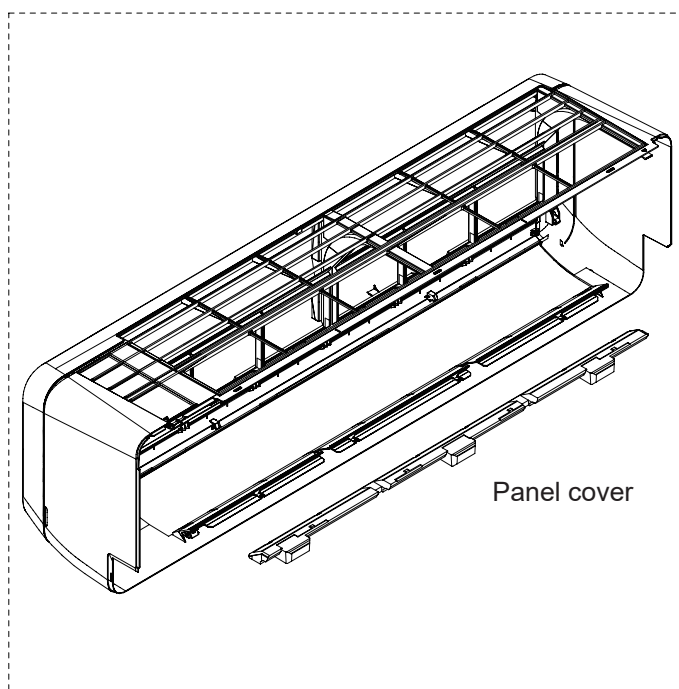

INDOOR UNIT
RSG18KMTA
RSG24KMTA

Ref.	Description	Part number
31	U/D louver assy	9387479010
32	Louver spring	9383730023

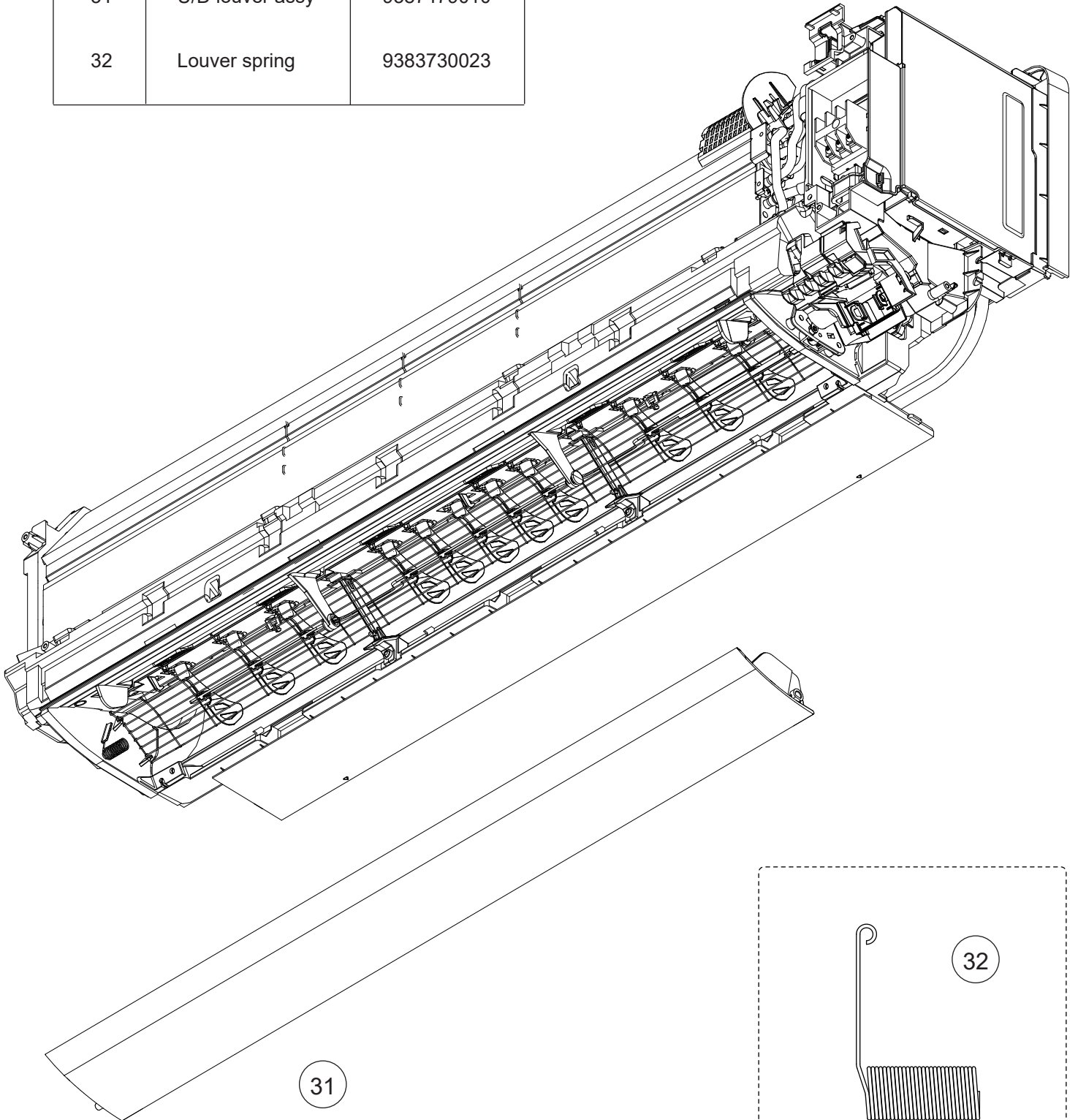
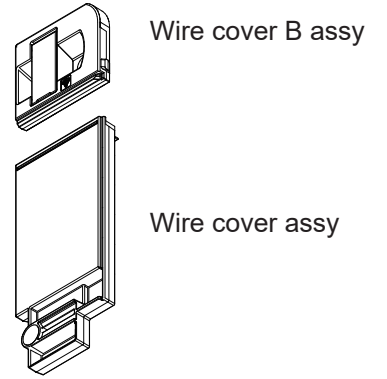

INDOOR UNIT
RSG18KMTA
RSG24KMTA

Control box

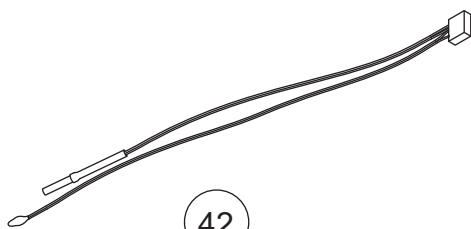
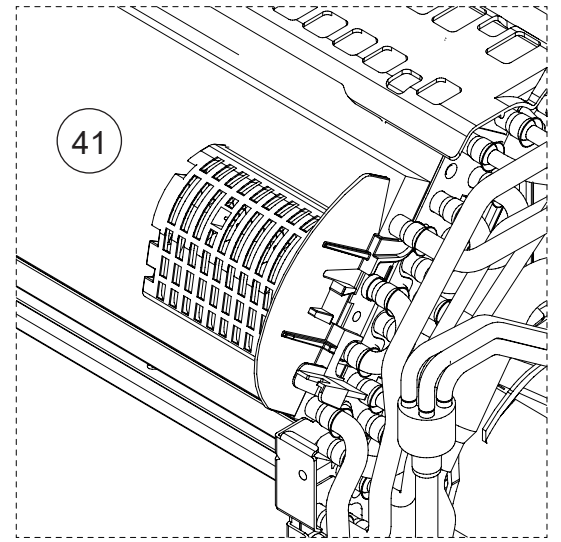
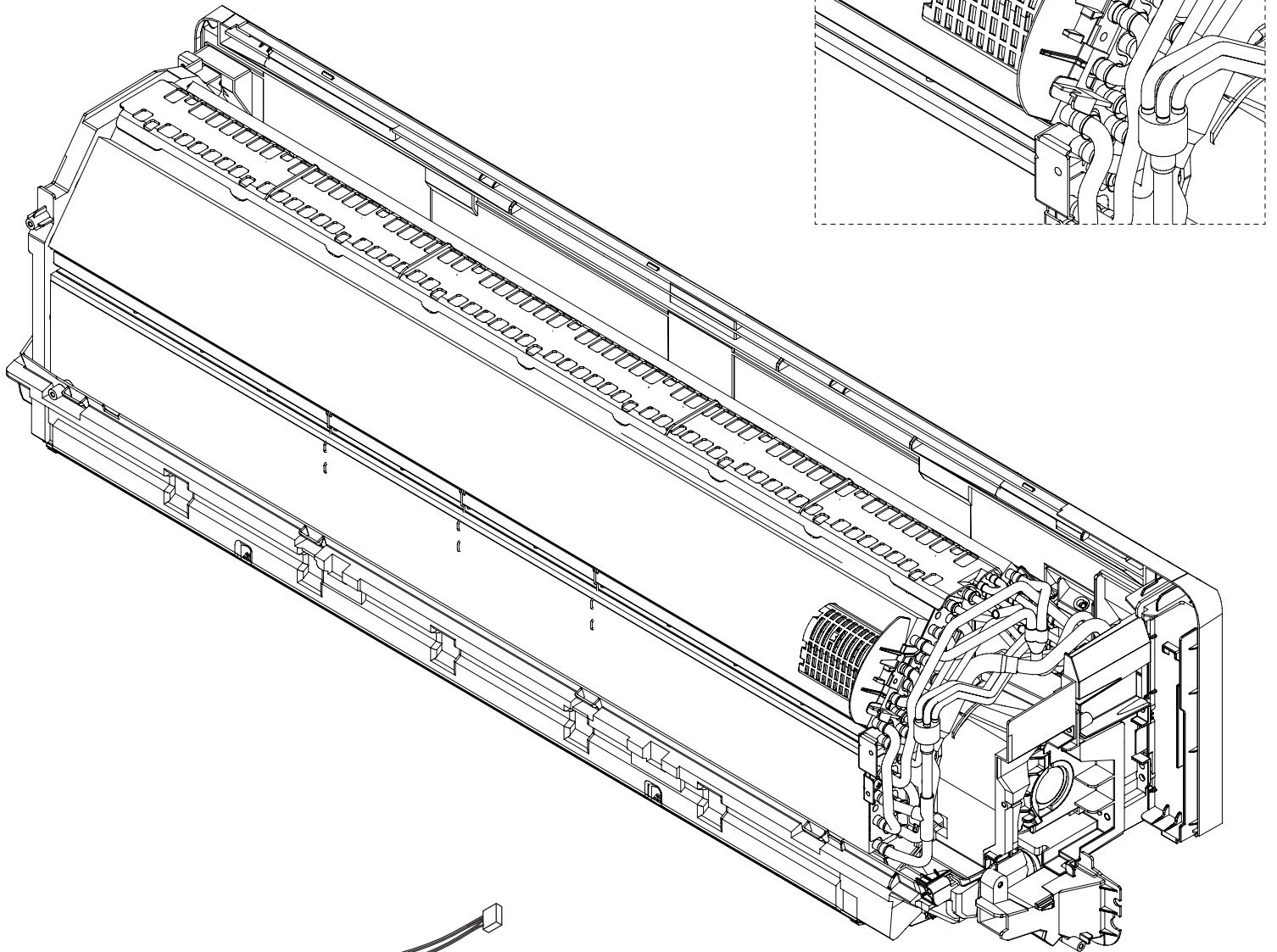

Wifi holder assy

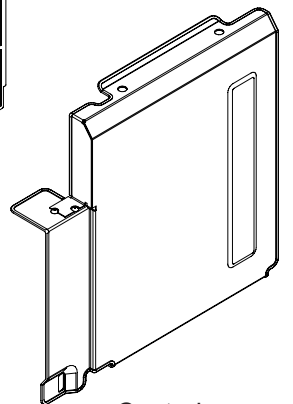
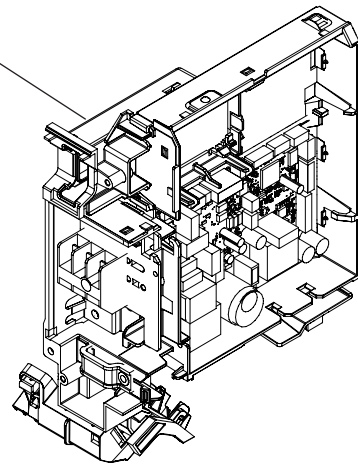

Control cover

Ref.	Description	Part number
41	Room thermistor holder	9387467000
42	Thermistor assy	9900627041

INDOOR UNIT
RSG18KMTA
RSG24KMTA

Control box

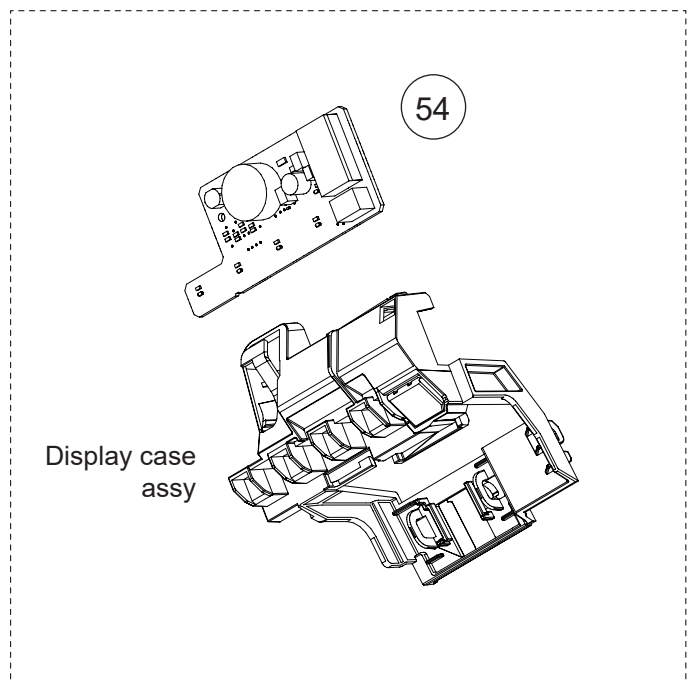
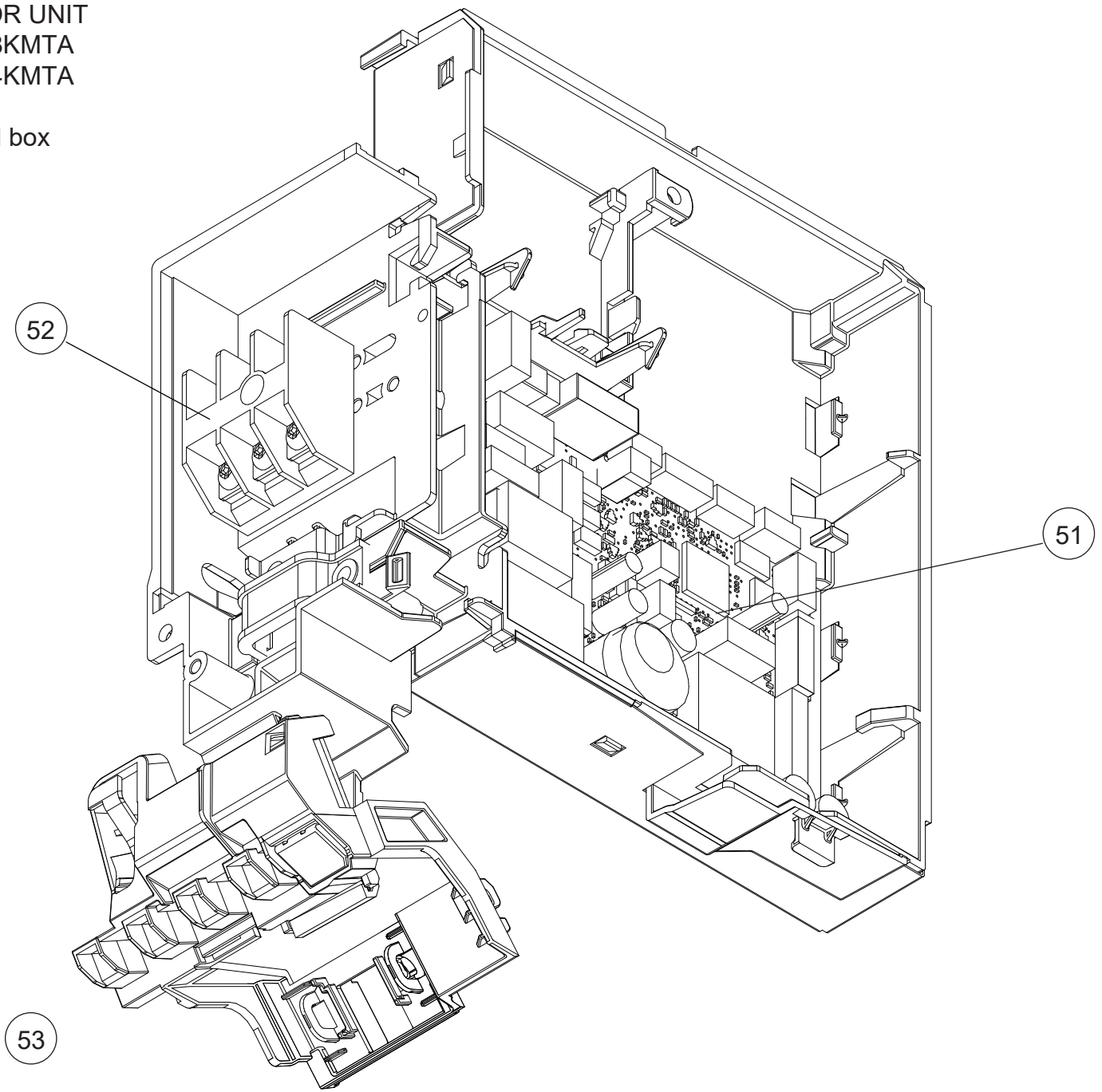

Ref.	Description	Part number
51	Main PCB (RSG18)	9711141118
51	Main PCB (RSG24)	9711141125
52	Terminal	9306489045
53	Display assy	9711146052
54	Indicator PCB	9711147011

INDOOR UNIT
RSG18KMTA
RSG24KMTA

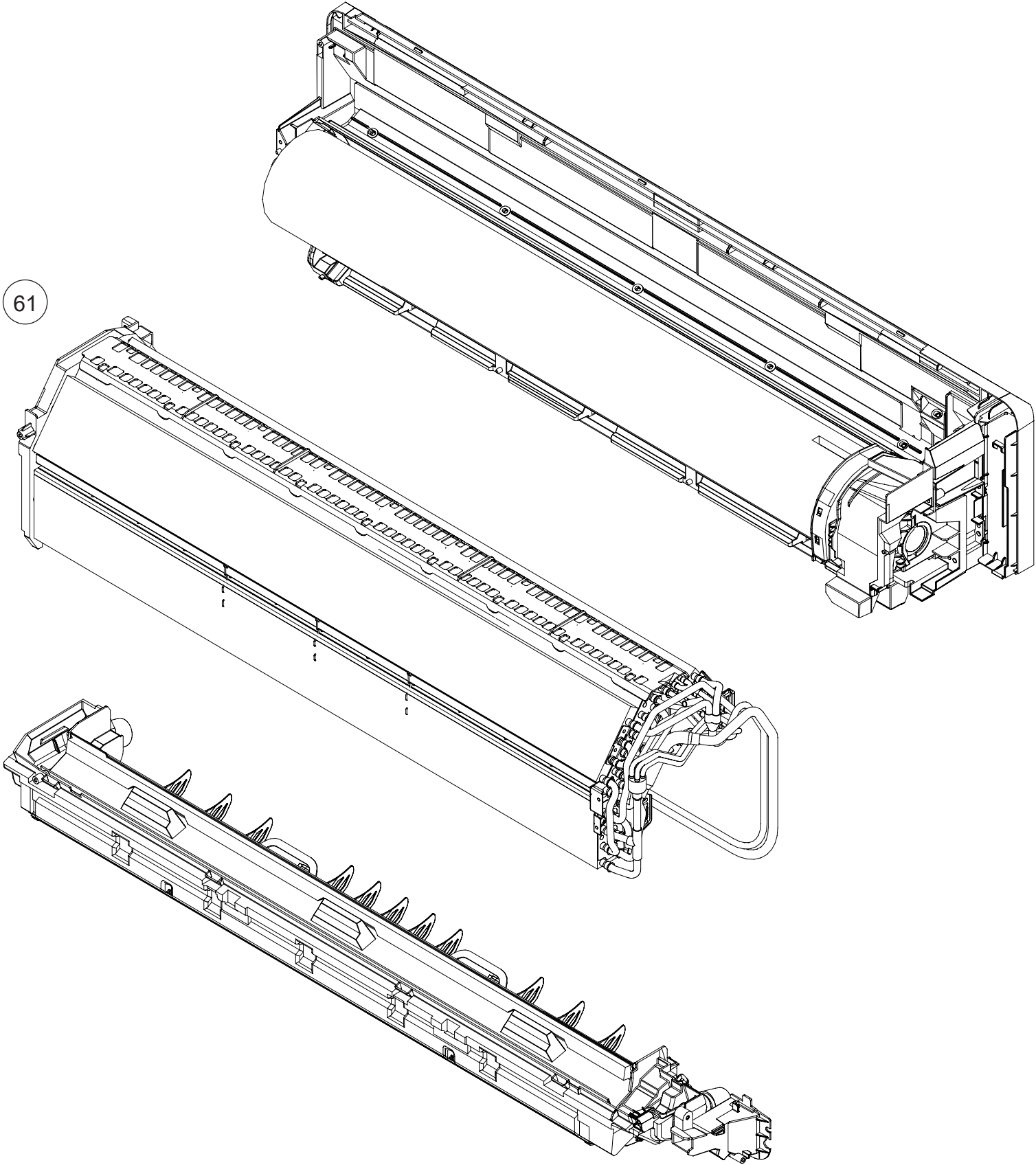

Ref.	Description	Part number
61	Evaporator total assy	9383735011

INDOOR UNIT
RSG18KMTA
RSG24KMTA

Base total assy
Motor cover assy
Fan motor

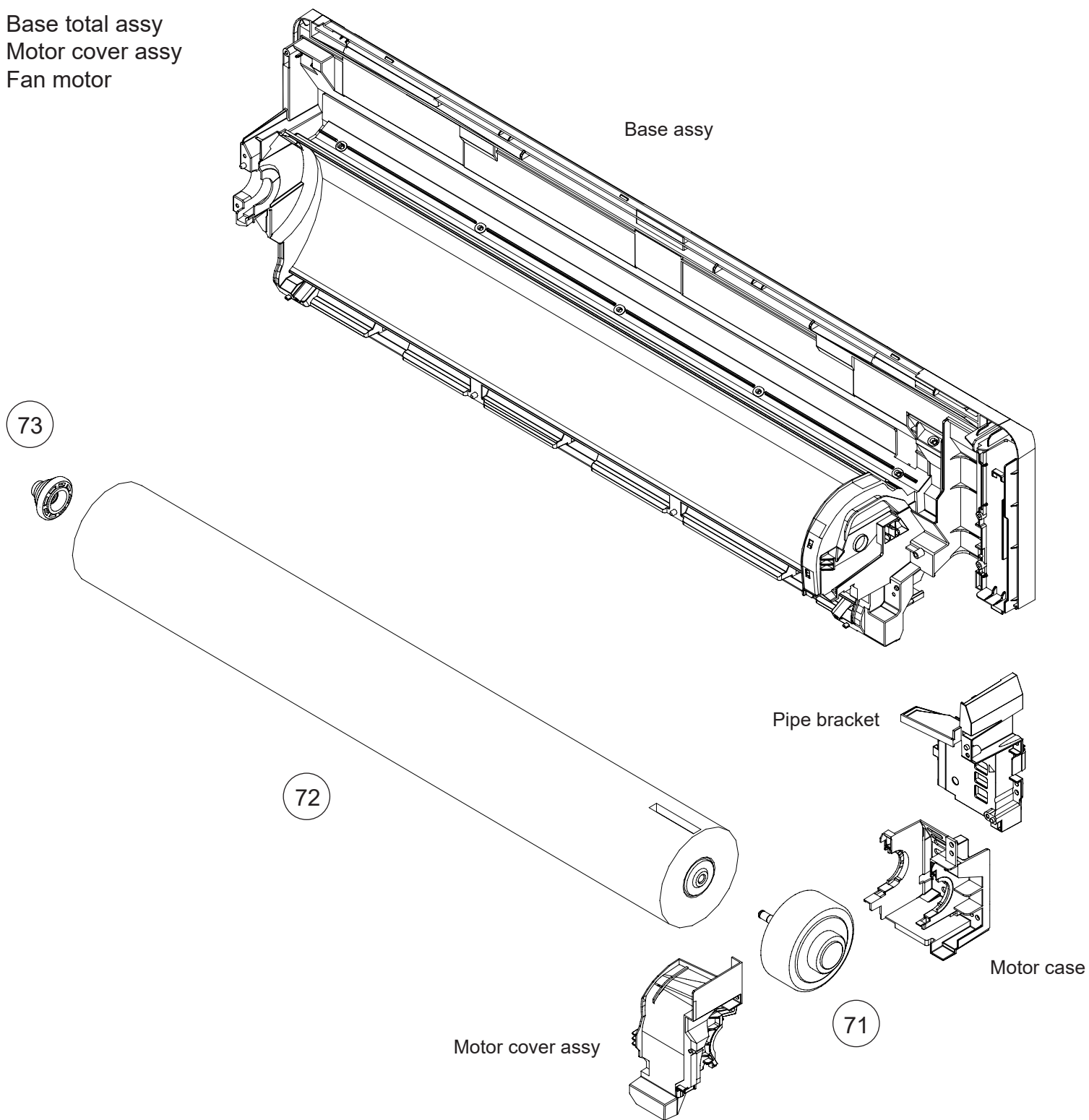

Ref.	Description	Part number
71	Brushless motor	9603631000
72	Crossflow fan assy	9387055030
73	Bearing D assy	9333628004

INDOOR UNIT
RSG18KMTA
RSG24KMTA

Drain pan total assy

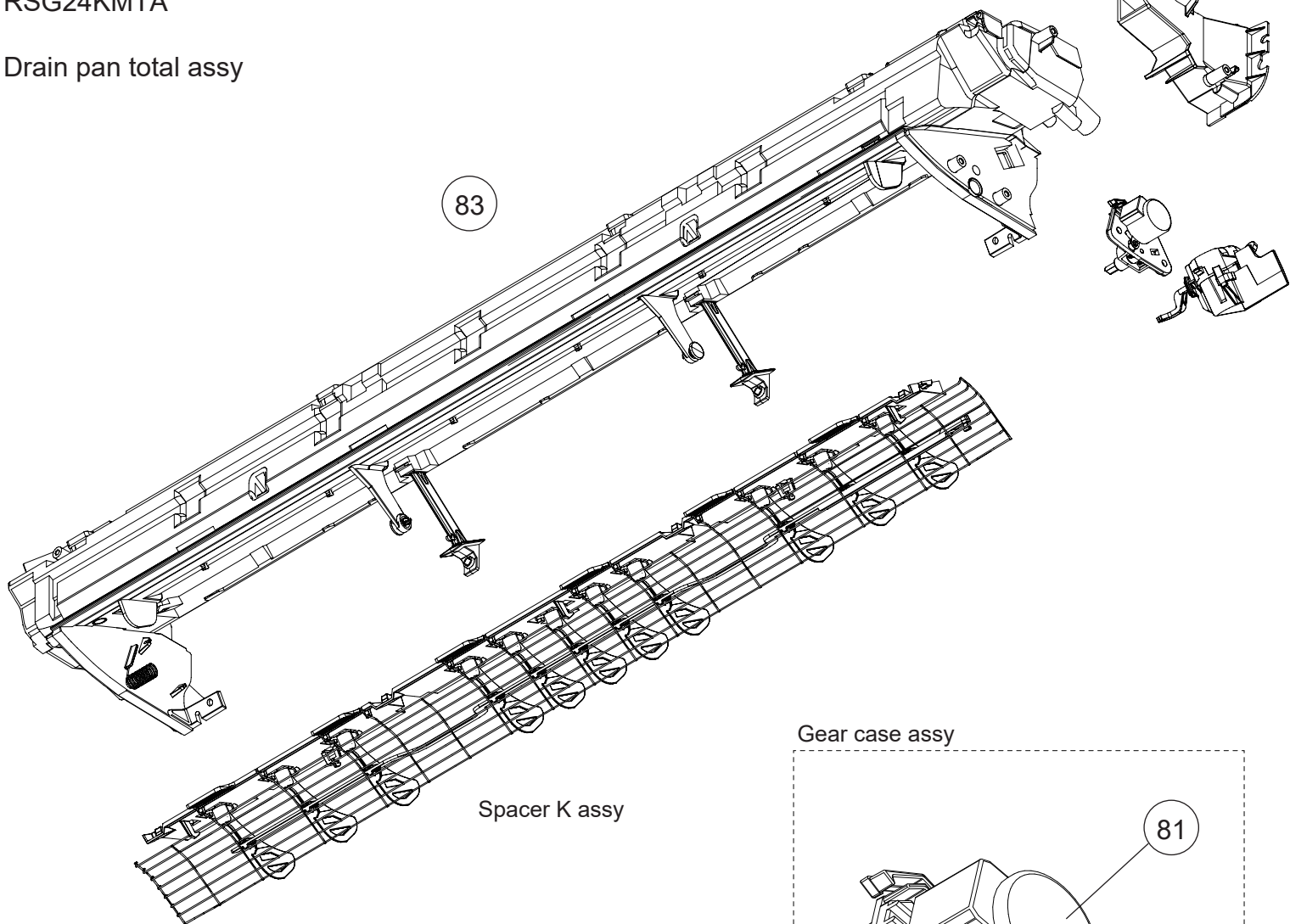

Gear case assy

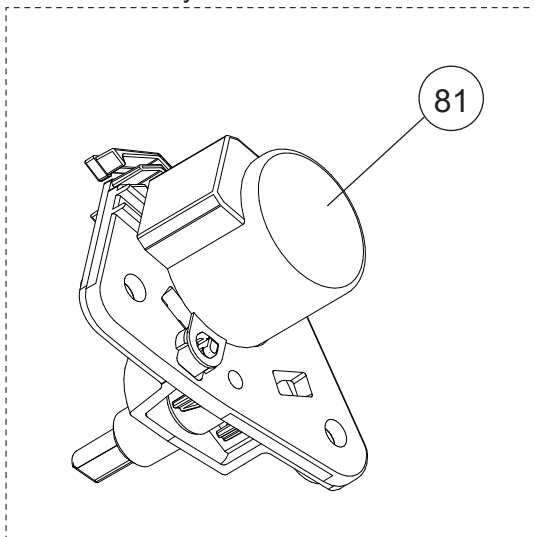

R and L louver SPM assy

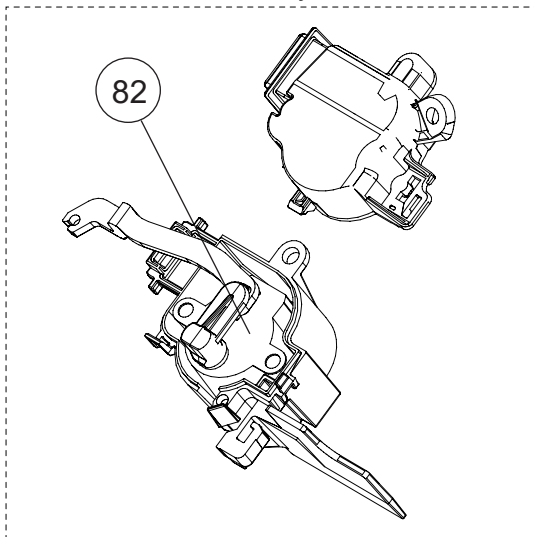

Ref.	Description	Part number
81	Stepping motor	9901011016
82	Stepping motor	9901011023
83	Drain pan assy	9387591019

Parts

OUTDOOR UNIT
ROG18KMTA

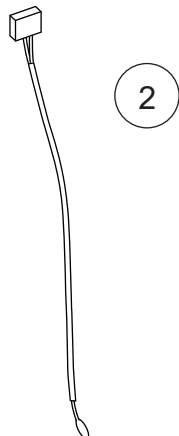
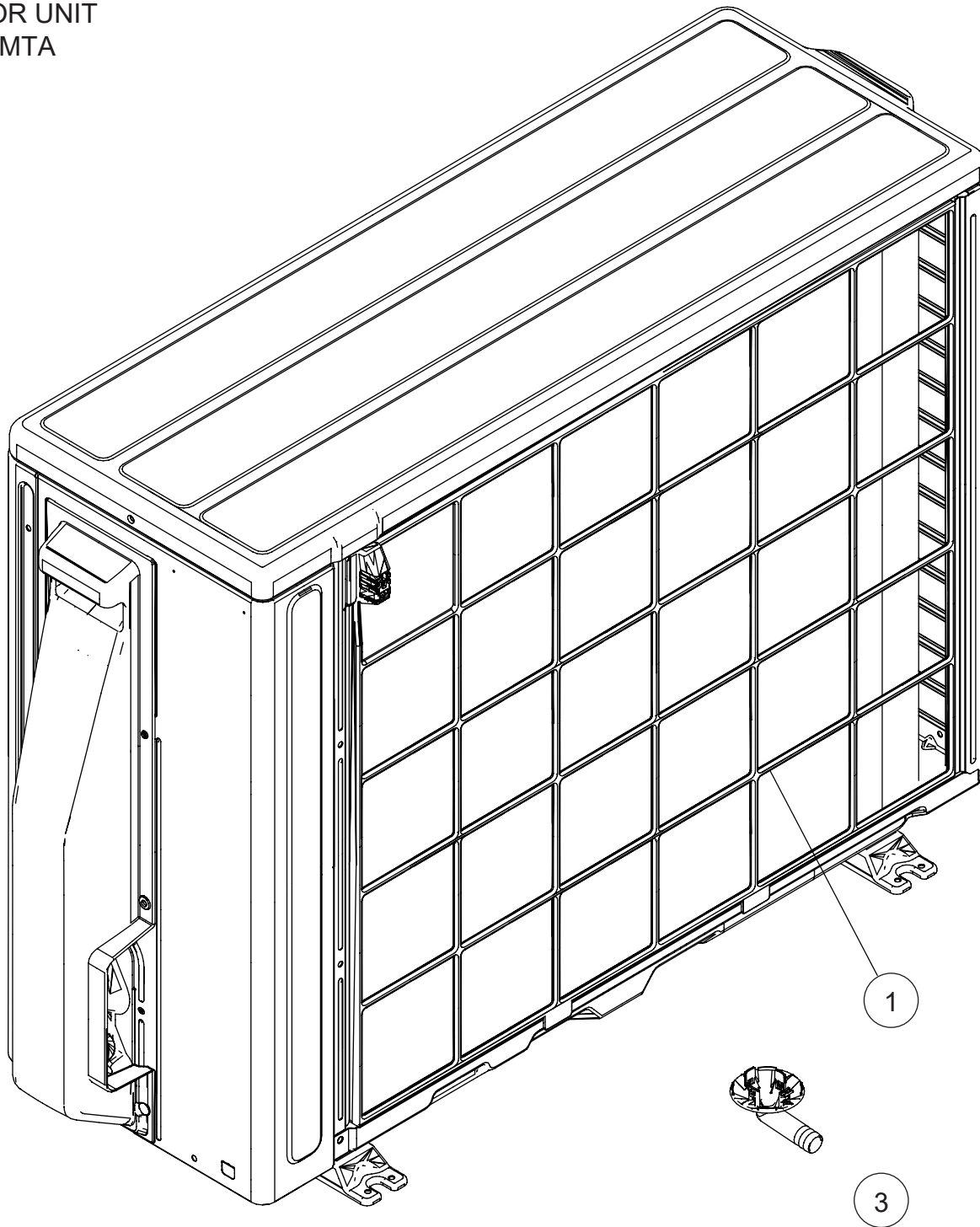

Ref.	Description	Part number
1	Protective net assy	9322811028
2	Outdoor thermistor	9900565060
3	Drain pipe	9322144003

OUTDOOR UNIT
ROG18KMTA

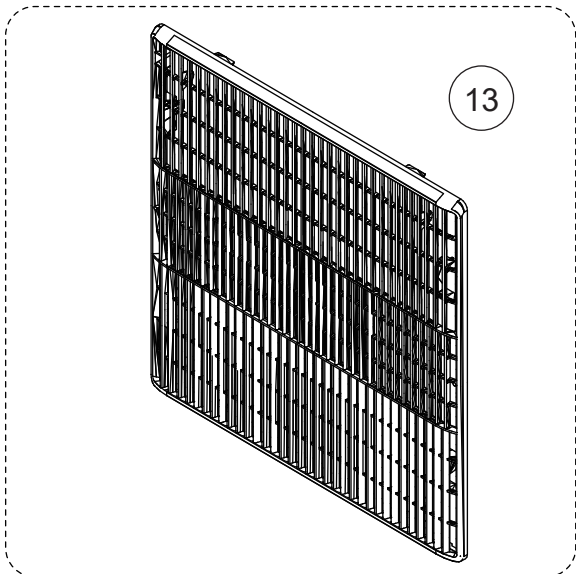
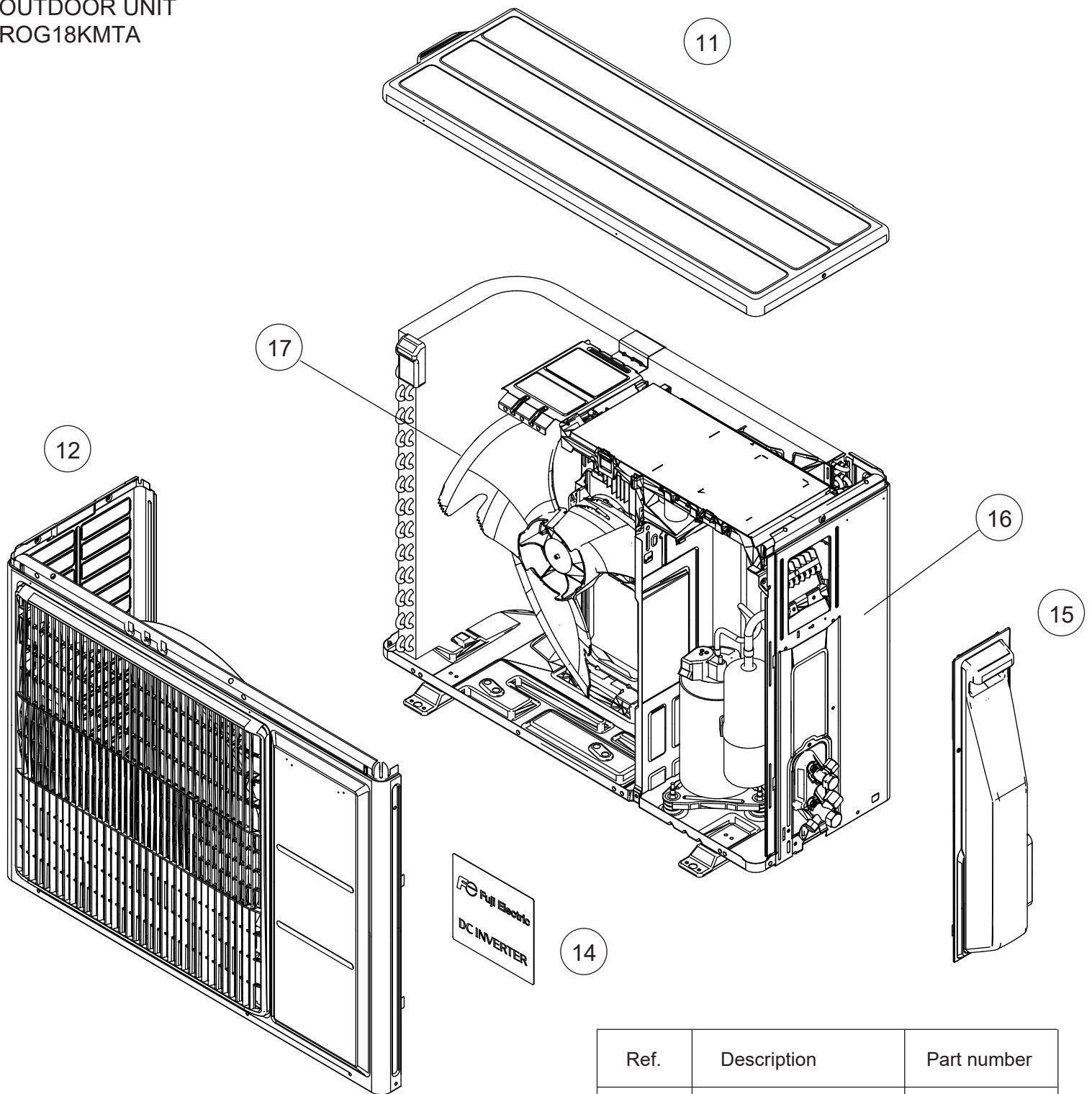

Ref.	Description	Part number
11	Top panel assy	9322556028
12	Front panel assy	9322555021
13	Blow grille	9322149008
14	Emblem	9319158006
15	Switch cover assy	9322570024
16	Cabinet right assy	9322552099
17	Propeller fan	9322150004

OUTDOOR UNIT
ROG18KMTA

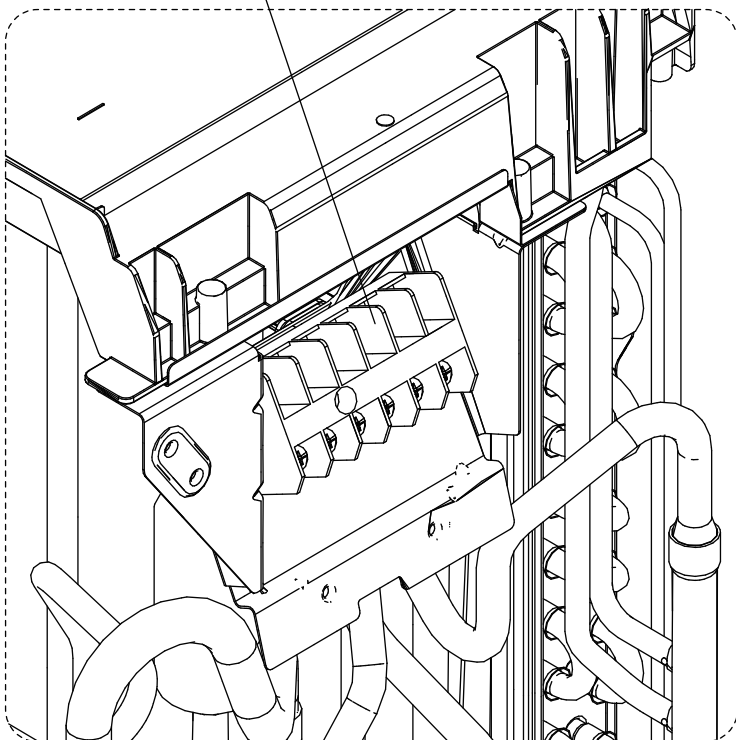
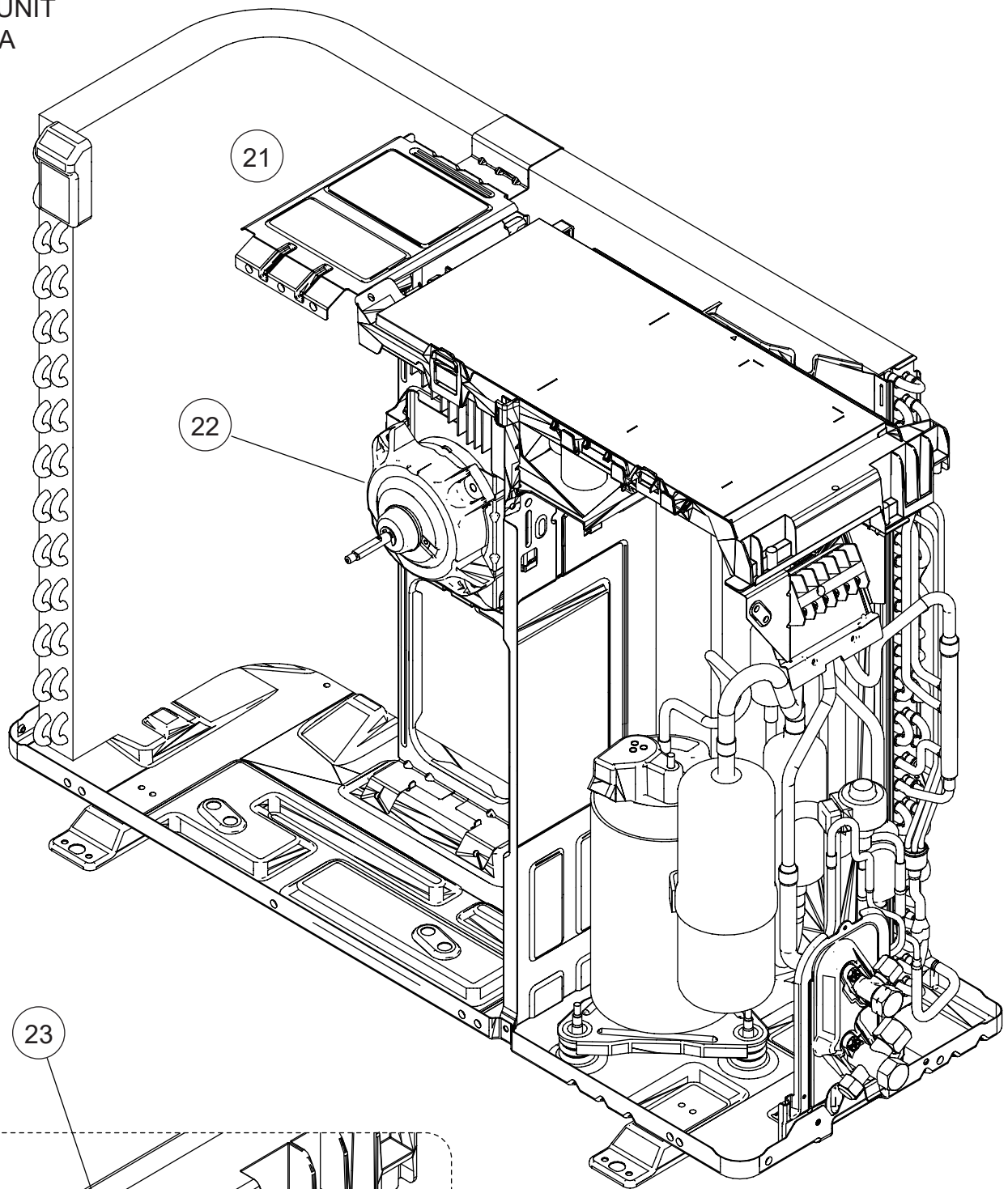

Ref.	Description	Part number
21	Motor bracket assy	9322553027
22	Brushless motor	9603601003
23	Terminal	9900435028

OUTDOOR UNIT
ROG18KMTA

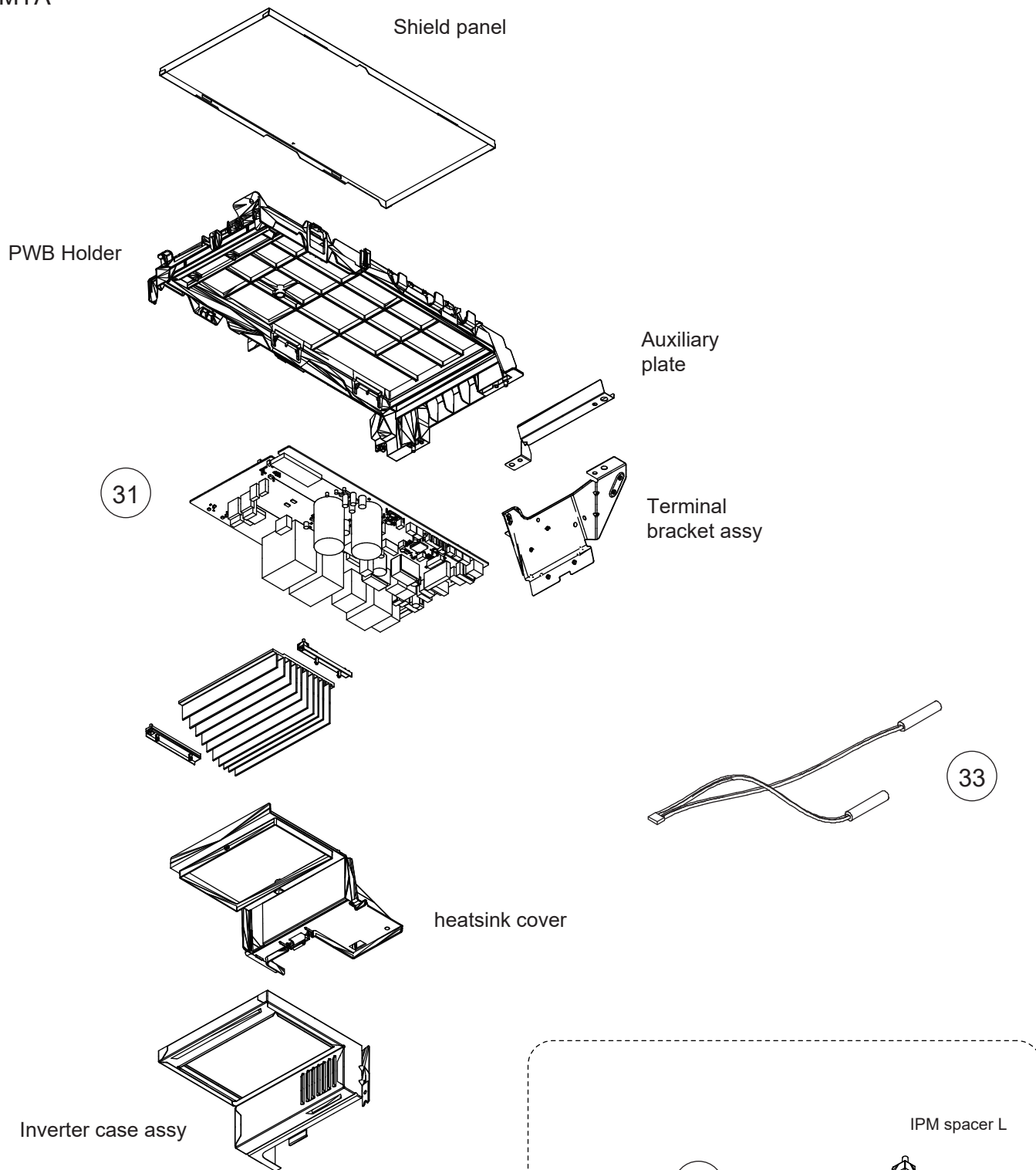

Ref.	Description	Part number
31	Main PCB	9710802140
32	Heatsink	9322420039
33	Thermistor assy	9900727079

OUTDOOR UNIT
 ROG18KMTA

Ref.	Description	Part number
41	Condenser total assy	9317089616
-	S-insulator B	9322500007
-	S-insulator F	9322847003
-	S-insulator H	9322501004
-	S-insulator V	9323045002

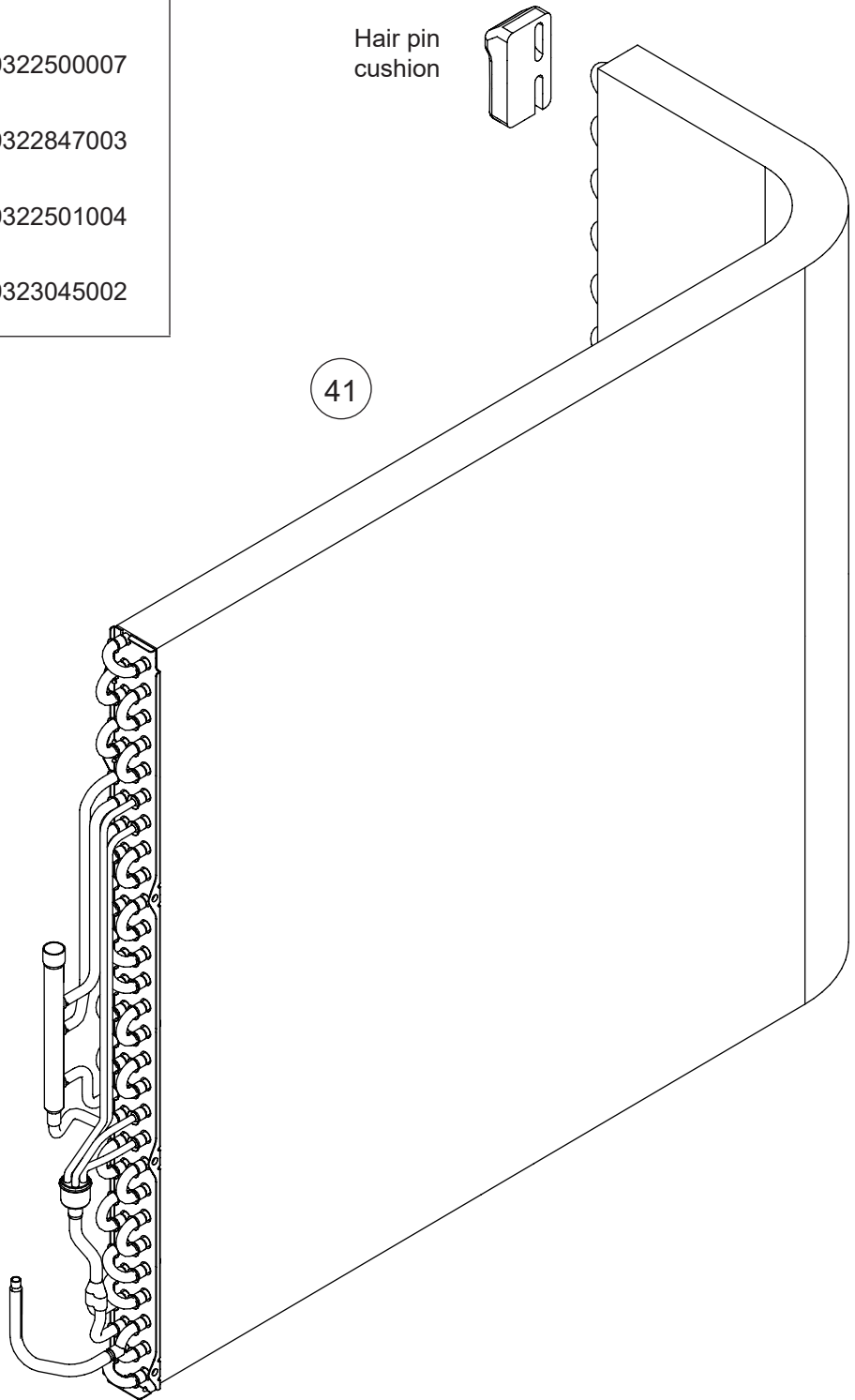
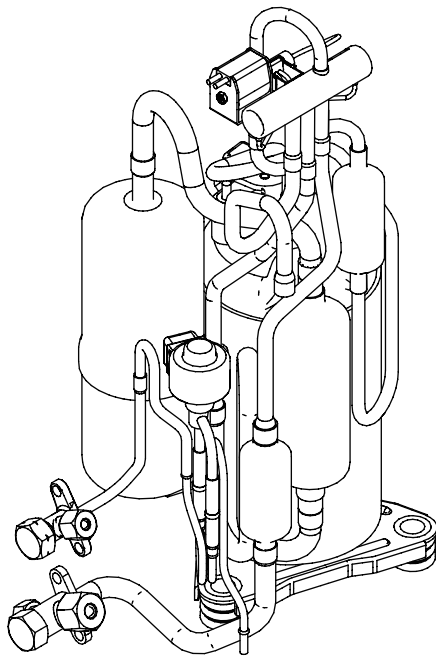

OUTDOOR UNIT
ROG18KMTA

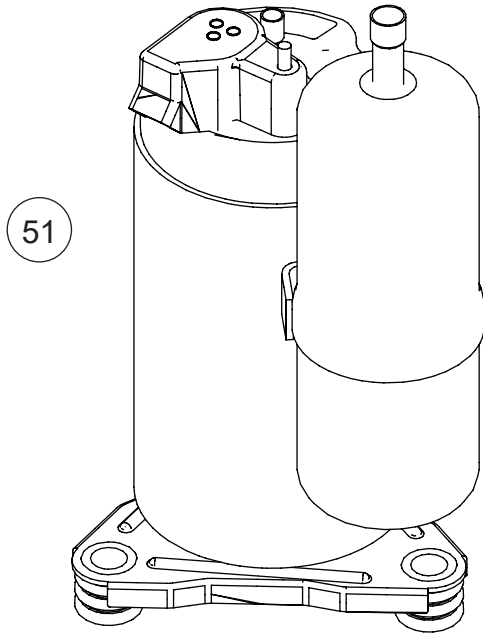

Rubber cushion

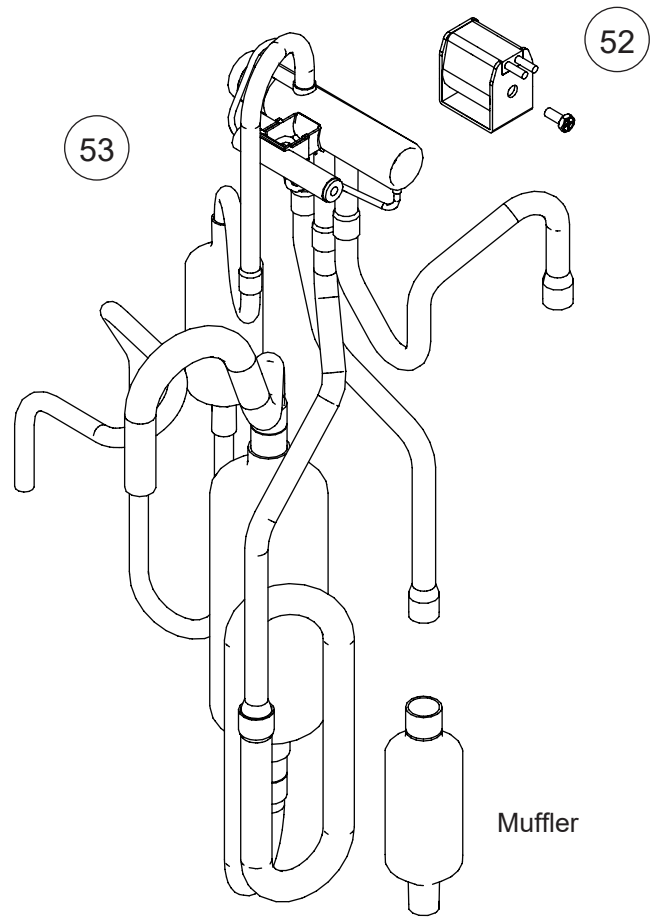

Muffler

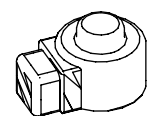
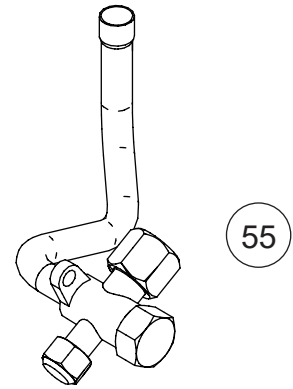

Ref.	Description	Part number
51	Compressor assy	9322433008
52	Solenoid	9970195006
53	4-way valve assy	9322783004
55	3-way valve assy	9387831016
56	Expansion valve coil	9970173028
57	Pulse motor valve assy	9322463029
58	2-way valve assy	9322474001

Parts

OUTDOOR UNIT
ROG24KMTA

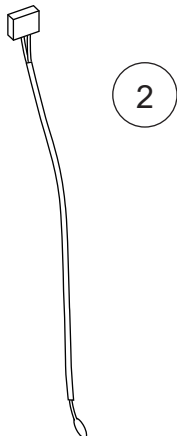
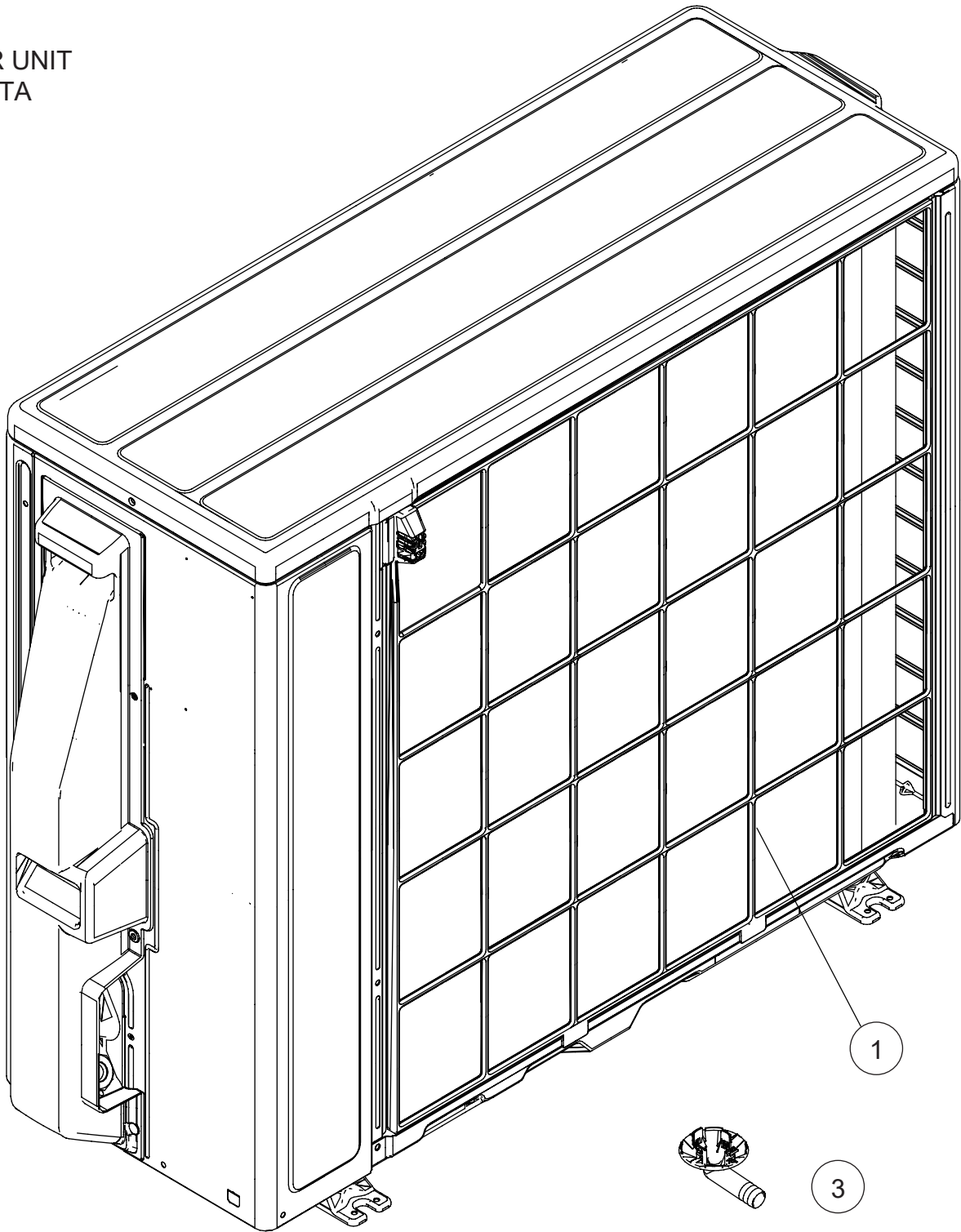

Ref.	Description	Part number
1	Protective net assy	9322811042
2	Outdoor thermistor	9900565060
3	Drain pipe	9322144003

OUTDOOR UNIT
ROG24KMTA

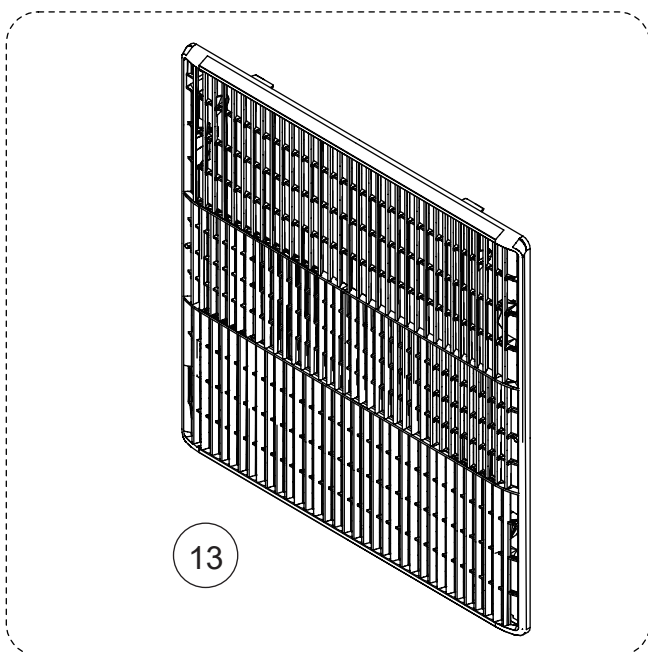
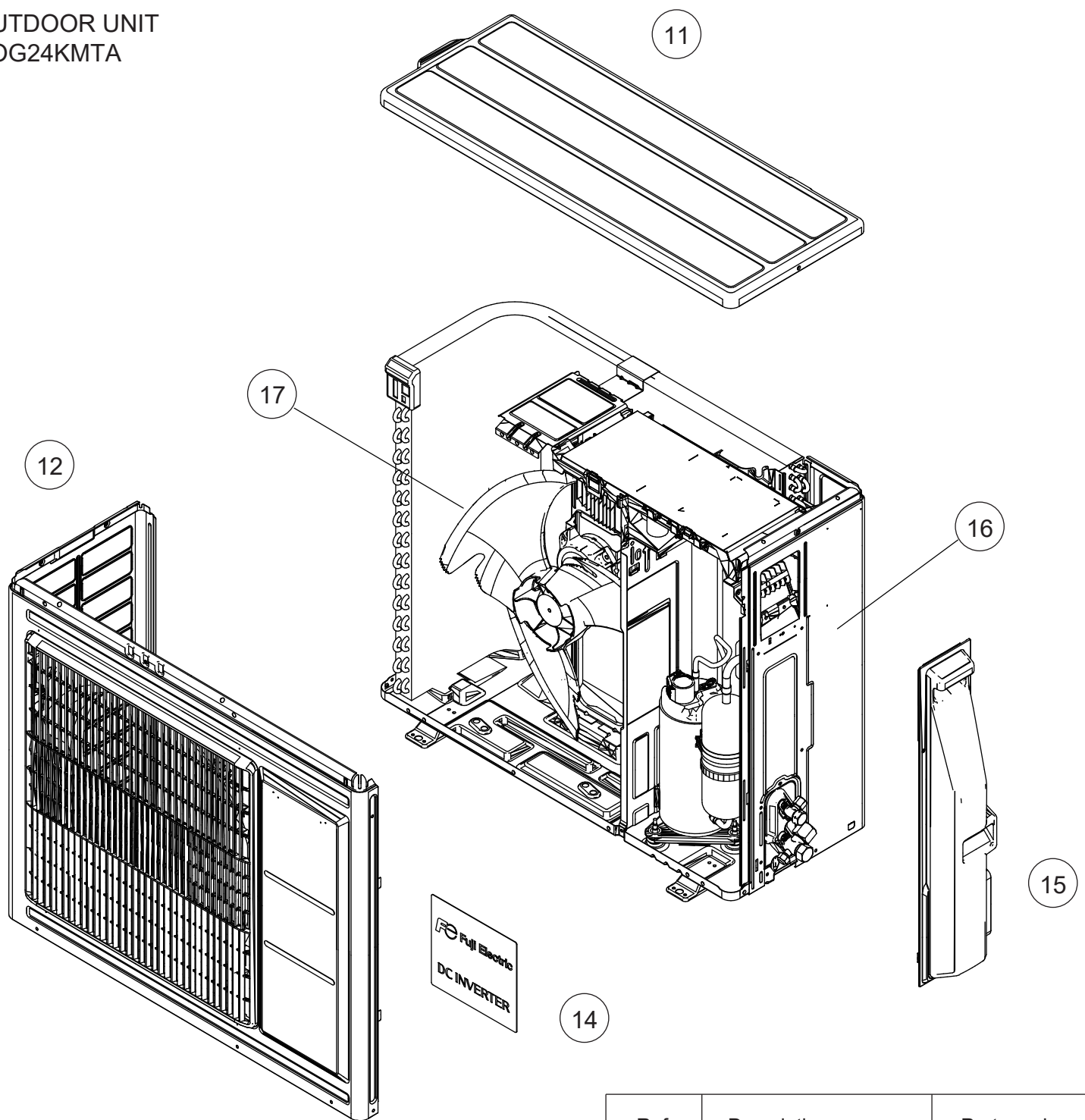

Ref.	Description	Part number
11	Top panel assy	9322556073
12	Front panel assy	9322555038
13	Blow grille	9322149008
14	Emblem	9319158006
15	Switch cover assy	9322570031
16	Cabinet right Assy	9322552150
17	Propeller fan	9322150004

OUTDOOR UNIT
ROG24KMTA

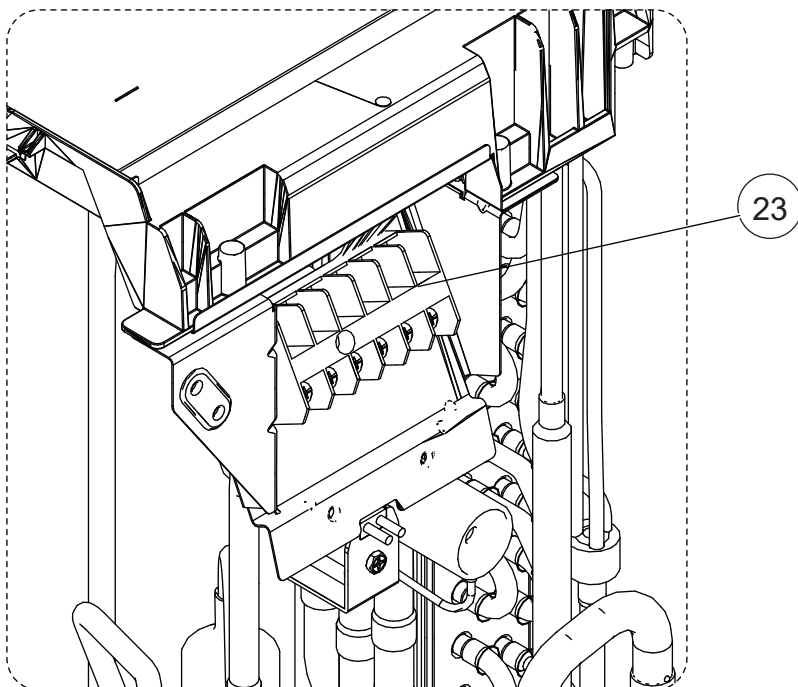
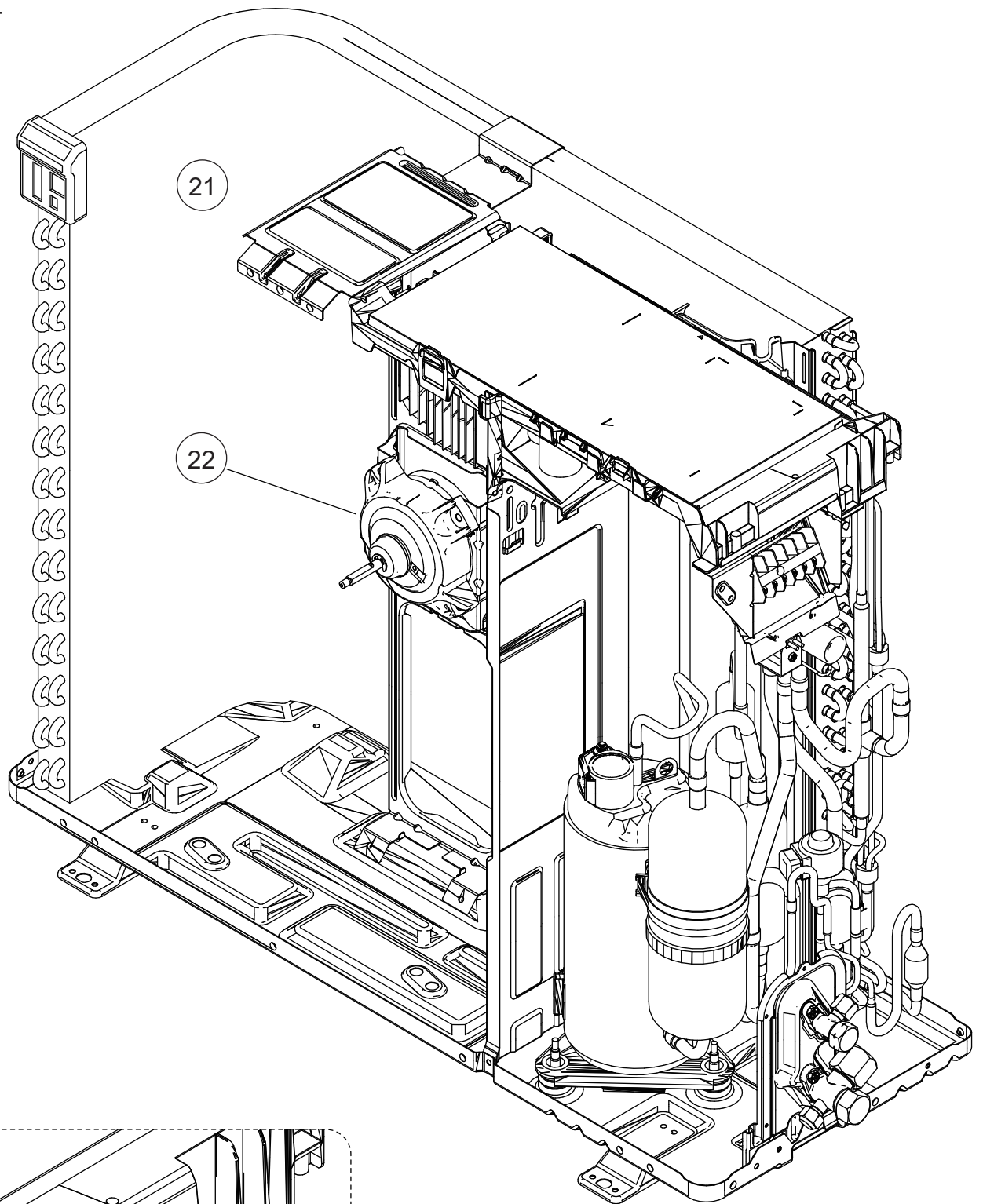

Ref.	Description	Part number
21	Motor bracket assy	9322553034
22	Brushless motor	9603601003
23	Terminal	9900435028

OUTDOOR UNIT
ROG24KMTA

Shield panel

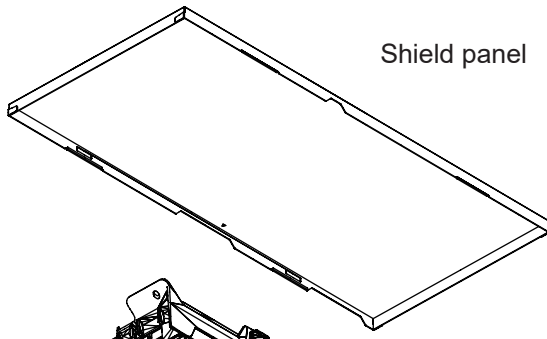

PWB Holder

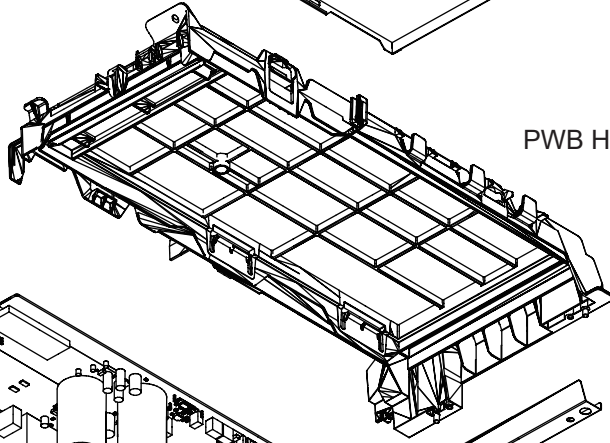

Auxiliary plate

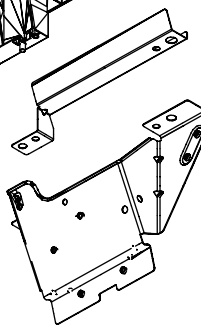

31

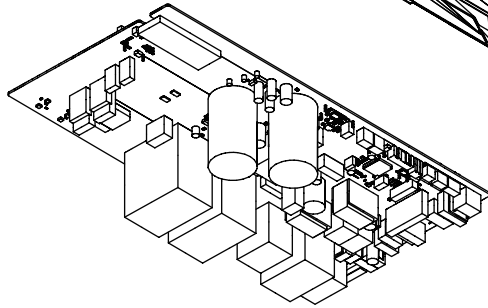

Terminal
bracket assy

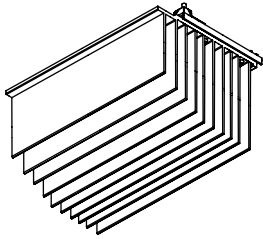

33

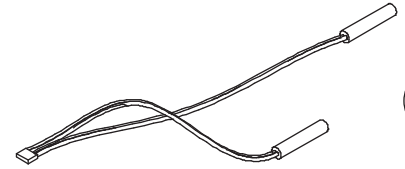

34

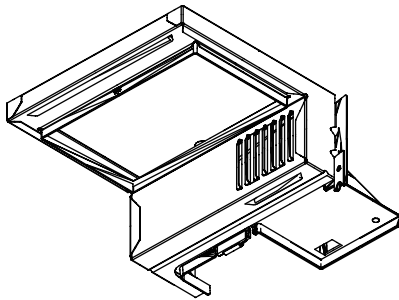
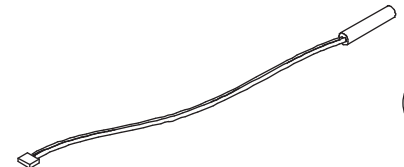

IPM spacer L

32

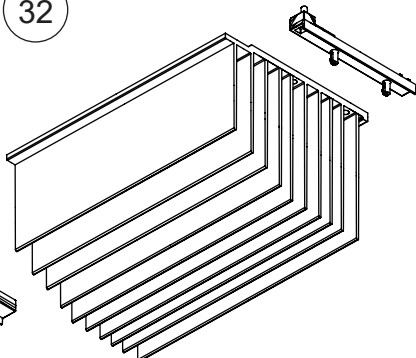

IPM
spacer R

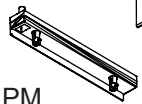

Ref.	Description	Part number
31	Main PCB	9710802270
32	Heatsink	9322421043
33	Thermistor assy	9900727116
34	Compressor thermistor	9900985011

OUTDOOR UNIT
ROG24KMTA

Ref.	Description	Part number
41	Condenser total assy	9317089630
-	S-insulator B	9322503008
-	S-insulator F	9322529008
-	S-insulator H	9322501004
-	S-insulator V	9323045002
-	S-insulator K	9322824004

Hair pin
cushion

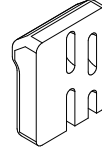

41

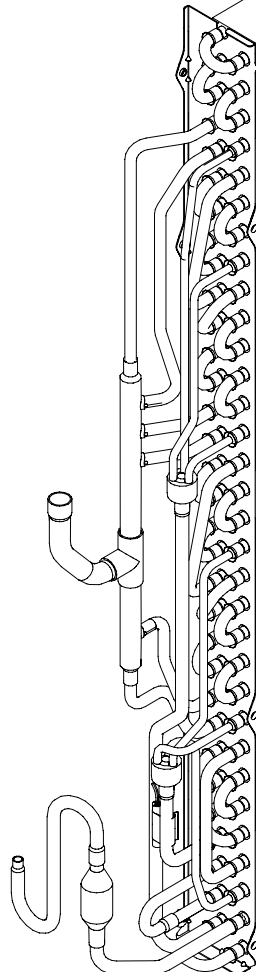
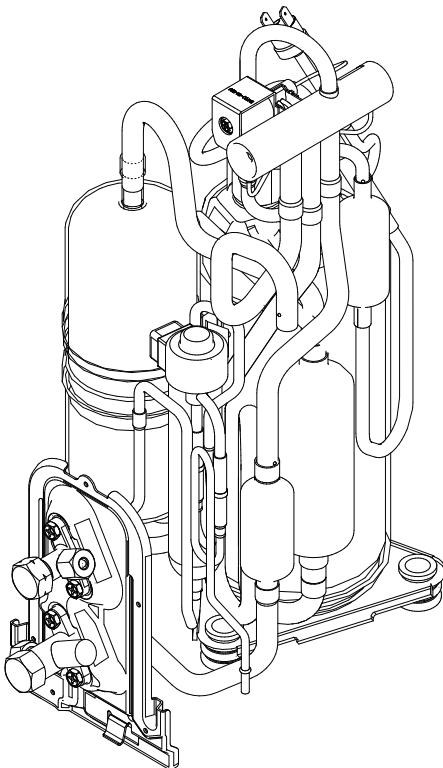

OUTDOOR UNIT
ROG24KMTA

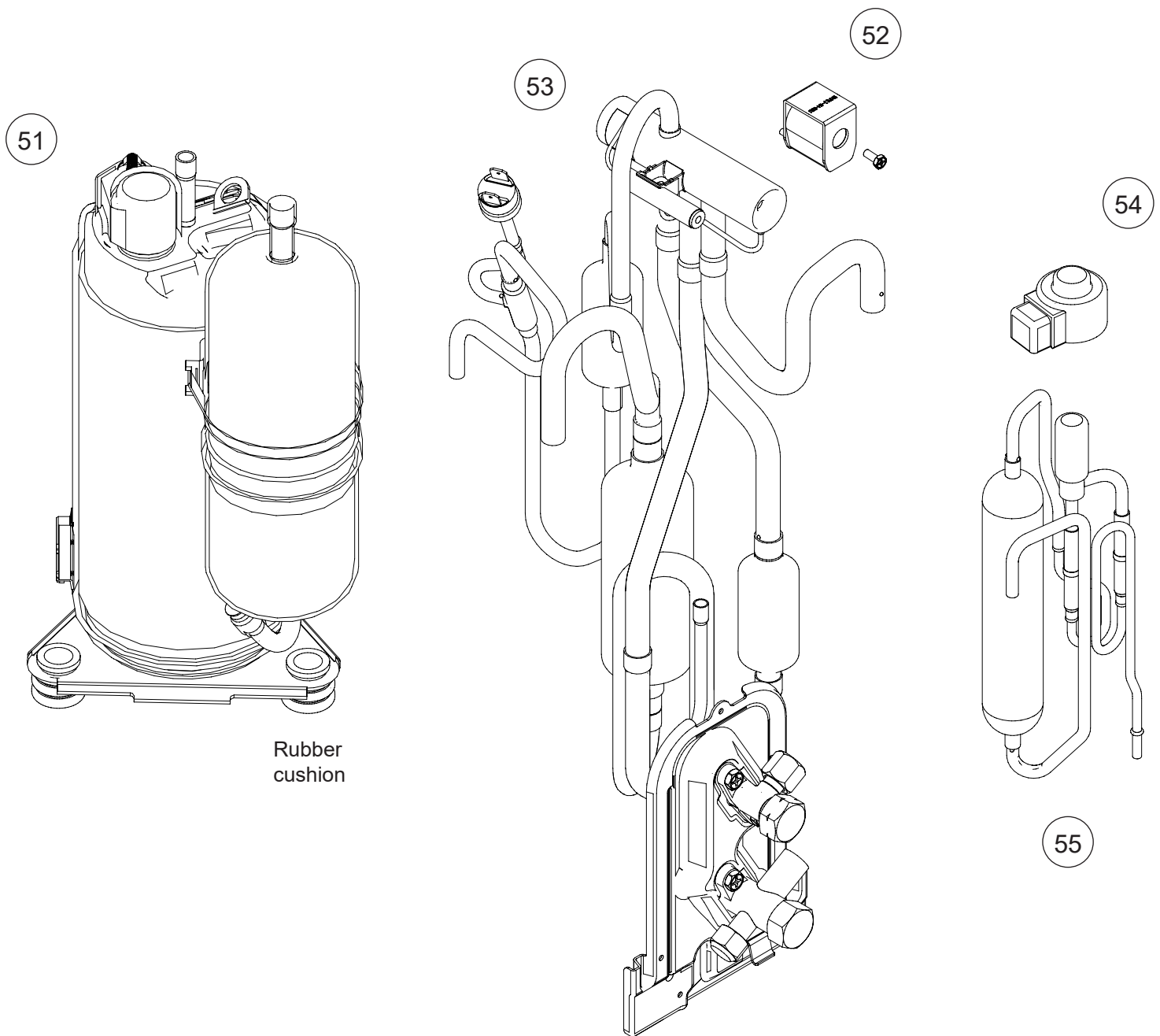







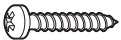

Rubber
cushion



Ref.	Description	Part number
51	Compressor	9810521002
52	Solenoid	9970206009
53	4-way valve assy	9383948008
54	Expansion valve coil	9970173028
55	Pulse motor valve assy	9322462015

Accessories

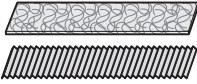
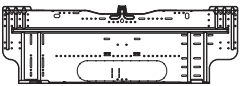
Models: RSG18KMTA and RSG24KMTA

Part name	Exterior	Q'ty	Part name	Exterior	Q'ty
Operating manual		1	Tapping screw (large)		5
Installation manual		1	Tapping screw (small)		2
Remote controller		1	Battery		2
Remote controller holder		1	Filter holder		2
Cloth tape		1	Air cleaning filters		1
Wall hook bracket		1			

Models: ROG18KMTA and ROG24KMTA

Part name	Exterior	Q'ty	Part name	Exterior	Q'ty
Installation manual		1	Drain pipe		1

1905G4818